

RS & RT

WORM GEAR BOXES

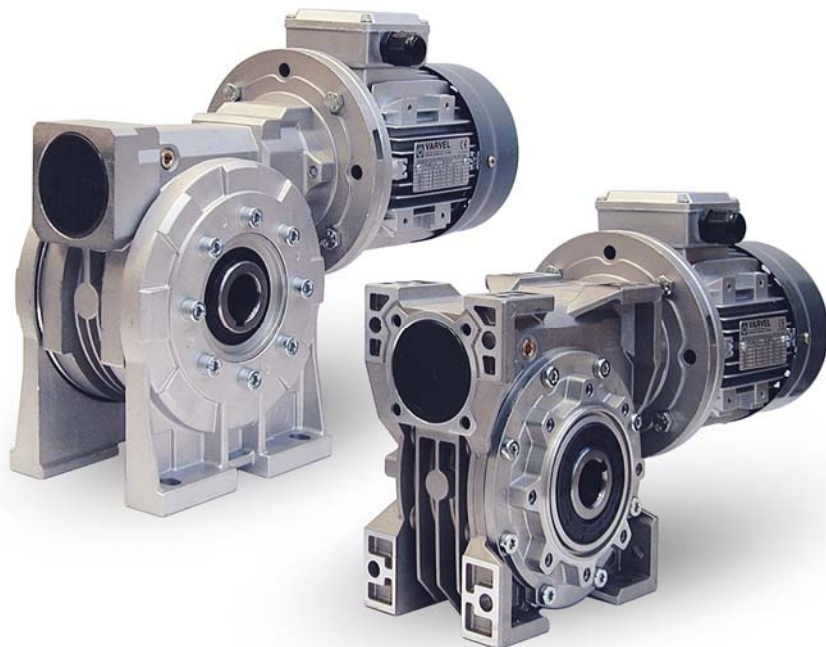

Gear boxes Series RS and RT

Product Description

Multipurpose housing

Aluminium die cast & Grey Iron
Modular for all mountings

Wormshaft

Z1 profile,
hardened and ground.
Alloy steel.

Wormwheel

Bronze cast
on cast iron hub.

Bearings

Ball or roller types.
Tapered roller bearings
for heavy duty operation.



Input

IEC and NEMA
motor adapters.
Universal elastic coupling
or traditional quill input.

Oil seals

NBR as standard;
VITON and SILICONE
on request.

Output

Hollow bore as standard.
Single or double solid shaft
on request.

Modular attachments

Helical one-stage gearbox, Output Flange,
Torque Arm & Torque Limiter.

Single worm gear boxes

The worm gearboxes, RS and RT series, specifically designed for universal mounting, are manufactured with die cast housings and covers in aluminium up to the size 85 and cast iron from the size 110.

Torques listed in selection tables are output torque values for the specific size, and motor powers are always referred to 1440 rpm.

Input Viton oil seals, fitted on request, allow free-trouble operation with 2-pole standard ac motors or 3000 rpm dc motors and Silicone oil seals for low temperatures.

Gearboxes are delivered filled with synthetic long-life oil (without plugs), in quantities as recommended on page 9, and valid for all mounting positions.

Selection table data are intended for service factor SF1.0 i.e. 8-10 running hours per day, uniform load, less than 6 start/ stops per hour, and room temperature ranging from 15 to 35 °C.

Helical worm gear boxes

The gearboxes, RA and TA series, made up of an independent single stage helical gearbox FXA fitted to a standard FRS or FTR gearbox, allow greater output torques and higher efficiency than the FRS and FRT gearbox with equivalent ratios.

Gear boxes Series RS and RT

Product Description

Two stage worm gear boxes

The gearboxes, RS/RS and RT/RT series, are made up of two gearboxes RS or RT and offer a full selection of high reduction ratios to obtain the very low output speeds.

AS, AD - Output shafts

All the gearboxes are manufactured with hollow output shaft as standard version and, optionally, a single AS or double AD solid output shaft - made of steel C43 - can be supplied.

An ASC safety shield for the opposite side of a single output shaft AS, is available on demand.

Torque arms

Standard gearboxes are supplied normally with covers on each side allowing torque arm fixing when gearboxes have to operate as shaft mounted units.

The torque arm, standard or with Vulkollan vibration-damping, is made of extra thick plate and white galvanized.

Directive ATEX

The gearboxes Series VARVEL-ATEX, delivered on request, are designed and manufactured according to Directive 94/9/CE « ATEX » and therefore, they are qualified for installation in potentially explosive atmospheres of:

- Zones of Group II,
- Category 2 (or 3),
- Explosion hazard with gas presence (Zones 1 or 2).

The gearboxes VARVEL-ATEX are identified by the marking:

 II 2 GD ck IP66 T_{max}=135 °C

Gear boxes Series RS and RT

Product Description

	GENERAL SPECIFICATIONS
Range	Sizes: 9 RS + 7 RT 55 reduction ratios 3020 Nm max. output torque
Sizing	According to BS721. 15,000 hrs average lifetime with service factor SF1
Housing, Covers	Pressure die cast aluminium AlSi12Cu2Fe till size 85 and cast iron from size 110.
Toothed parts	Worms of steel 20MnCr5 CH and tooth profile ZK ground. Wheels of bronze CuSn12 on CI hub.
Shafts & Keys	Steel C43 Shafts h6 - Bores E8 Keys according to DIN6885 B1
Bearings	Ball- or roller-types according to sizes and technical requirements
Oil seals	Type NB - nitrile-butadiene with additional anti-dust lip according to DIN 3760
Lubricant	Synthetic long-life oil Grade ISO VG 320
Baking painting	RS/RT \geq 110: epoxy powder paint, standard colour RAL 7012. RS/RT28-85: real aluminium.

Gear boxes Series RS and RT

Designation

GEAR BOX DESIGNATION

F | SR | [../] | 40 | B3 | 28 | IEC71 | B14 | (OPS, OPP)

OPS = Standard Options, pages 34-42
OPP = Options at the foot of the page

B5, B14 = Motor form

Motor frame

Reduction ratio

Gear box munting

Gear box size

RS (28, 40, 50, 60, 70, 85, 110, 130, 150) - RT (28, 40, 50, 60, 70, 85, 110)

Helical stage size RA (63/, 71/, 80/, 100/)

1st stage size (28/, 40/, 50/, 60/, 70/)

Gear box size

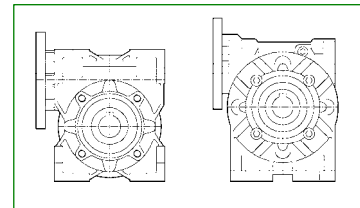

- M = Geared motor
- F = IEC input flange
- S = without IEC flange
- ... = Nothing - Input free shaft

MOTOR DESIGNATION

MT | 0,37 kW | 71b4 | B14 | 230/400/50 | IP55 | F | X1

Terminal box position

Cl. F (std) = Insulation class

IP55 (std) = Protection

Voltage / frequency

B5 or B14 = Mounting

IEC size and number of poles

Power

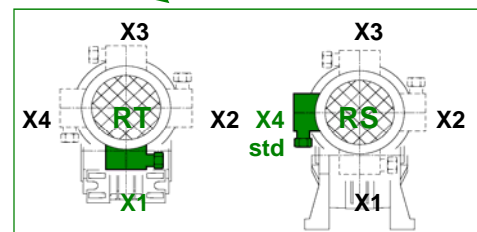

- MT = Three-phase motor
- MM = Single-phase motor
- MA = Brake motor

OPTIONS OPP

The standard fitting side, unless otherwise requested, is the gearbox right side when seen from input.

- ACØ - Not std hollow shaft Ø... mm
- CS - Not std output bearings
- FL - Additional output flange FL

- GRM - Reduced end play
- LNS - Not std lubrication
- VB - NDE wormshaft extension



Gear boxes Series RS and RT

RS

Mounting positions

RS , RA , RS/RS

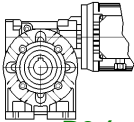
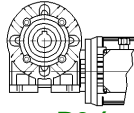
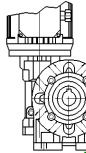
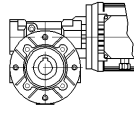
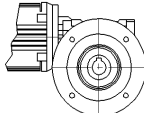
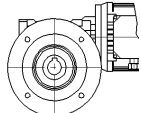
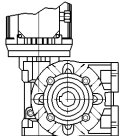
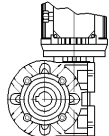
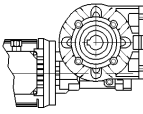
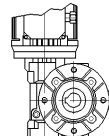
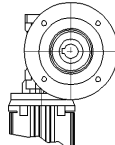
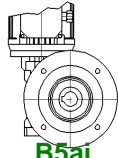
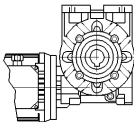
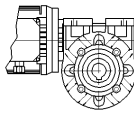
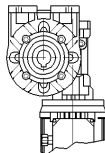
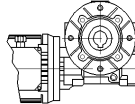
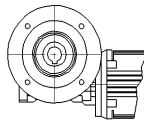
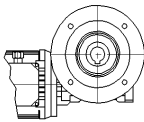
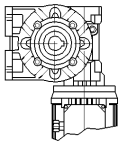
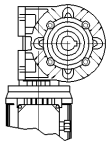
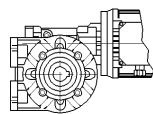
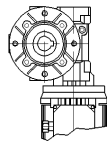
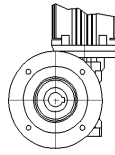
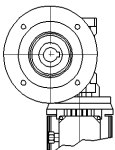
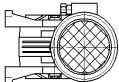
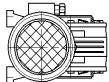
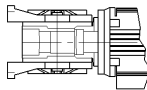
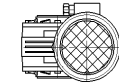
Output

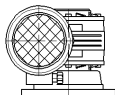
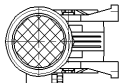
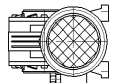
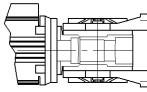
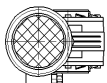
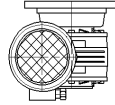
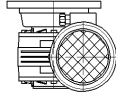
S - SA	I - IA	D - DA	PC - PC	FL - FA - FB - PA - PB	
 B3 (std)	 B3 (std)	 B3 (std)	 B5 (std)	 B5 (std)	 B5i
 V5	 V5	 V5	 B5	 B5a	 B5ai
 B8	 B8	 B8	 B5	 B5b	 B5bi
 V6	 V6	 V6	 B5	 B5c	 B5ci
 B6	 B6	 B6	 V1	 V1	 V1i
 B7	 B7	 B7	 V3	 V3	 V3i

RA

Input

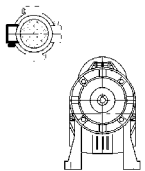
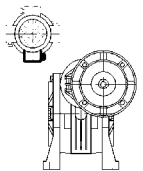
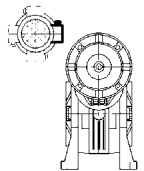
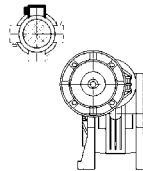
 10 (std)	 11	 12	 13		
--	--	--	--	--	--

RS

Gear boxes Series RS and RT

Mounting positions

RS / RS

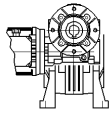
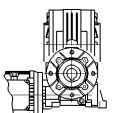
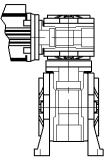
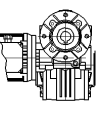
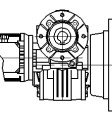
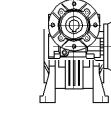
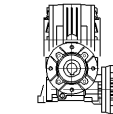
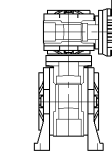
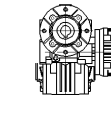
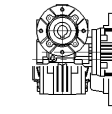
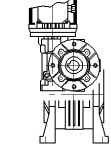
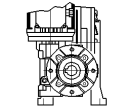
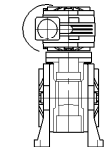
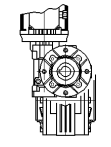
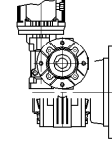
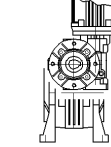
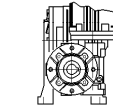
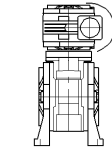
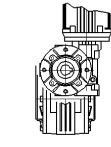
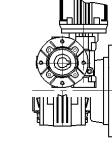
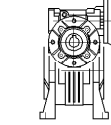
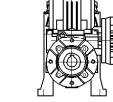
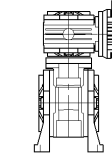
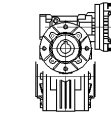
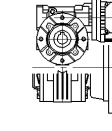
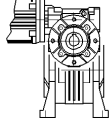
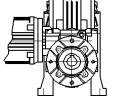
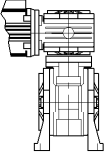
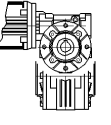
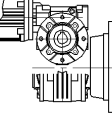
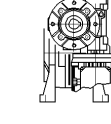
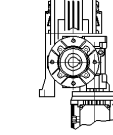
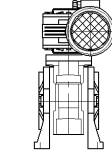
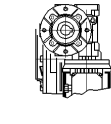
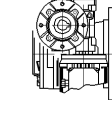
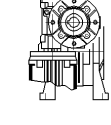
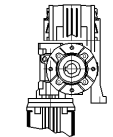
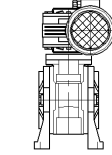
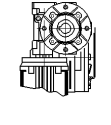
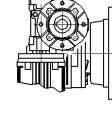

Output

	S - SA	I - IA	D - DA	PC - PA - PB	FL - FA - FB
11					
12					
13					
14					
15					
16					
17					
18					

Gear boxes Series RS and RT

RT

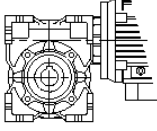
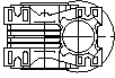
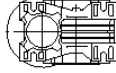
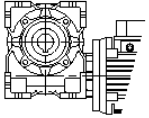
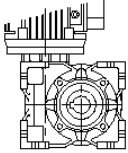
Mounting positions

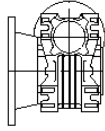
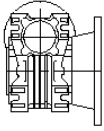
RT TA RT/RT Output	 <p>B3 (std)</p>	 <p>B6</p>	 <p>B7</p>	 <p>B8</p>
	 <p>V5</p>	 <p>V6)</p>	 <p>F (std)</p>	 <p>Fi</p>

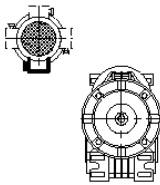
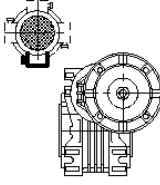
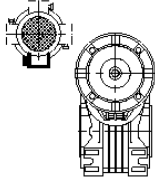
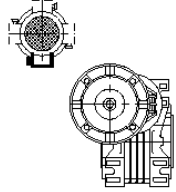
TA Input	 <p>10 (std)</p>	 <p>11</p>	 <p>12</p>	 <p>13</p>
--------------------	--	--	---	--

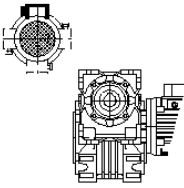
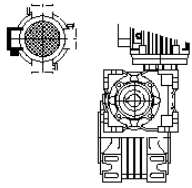
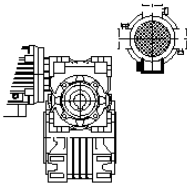
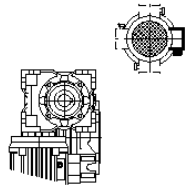
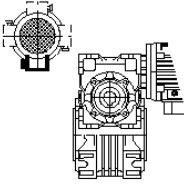
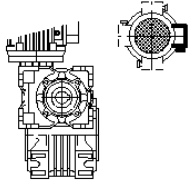
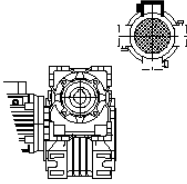
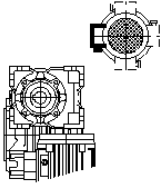
RT/RT Input	 <p>20 (std)</p>	 <p>21</p>	 <p>22</p>	 <p>23</p>
	 <p>24</p>	 <p>25</p>	 <p>26</p>	 <p>27</p>

Gear boxes Series RS and RT

Service Factors - Weights - Lubricants

SERVICE FACTORS

$$FS = F_1 \times F_2$$

Load type F_1	uniform	variable	shocks	Starts/ stops F_2	Starts per hour
3 - 4 h	0.8	1.0	1.5	6	1.0
8 - 10 h	1.0	1.2	1.8	60	1.2
10 - 24 h	1.4	1.6	2.0	120	1.4

WEIGHTS AND LUBRICANTS (litres)

RS - RT	kg	l	RA - RT	kg	l ₁ / l ₂	RS / RS RT / RT	kg	l ₁ / l ₂
28	1.1	0.03	63 / 40	4.0	0.04/0.08	28 / 28	2.5	0.03/0.03
40	2.5	0.08	63 / 50	5.3	0.04/0.13	28 / 40	3.9	0.03/0.08
50	3.8	0.13	63 / 60	8.0	0.04/0.23	28 / 50	5.2	0.03/0.13
60	6.5	0.23	71 / 50	6.6	0.05/0.13	28 / 60	7.9	0.03/0.23
70	9.0	0.35	71 / 60	9.3	0.05/0.23	40 / 70	12.0	0.08/0.35
85	13.5	0.60	71 / 70	11.8	0.05/0.35	40 / 85	16.5	0.08/0.60
110	39.0	1.50	71 / 85	16.3	0.05/0.60	50 / 110	45.0	0.13/1.50
*130	50.0	2.75	80 / 60	10.5	0.10/0.23	*60/130	57.0	0.23/2.75
*150	80.0	4.40	80 / 70	13.0	0.10/0.35	*70/150	90.0	0.35/4.40
			80 / 85	17.5	0.10/0.60			
			80 / 110	43.0	0.10/1.50			
			100/110	46.0	0.20/1.50			
			*100/130	64.0	0.20/2.75			
			*100/150	94.0	0.20/4.40			

* only RS

XA	kg	l
63	1.5	0.04
71	2.2	0.06
80	3.0	0.10
100	7.0	0.20

Gear boxes Series RS and RT

Input external loads

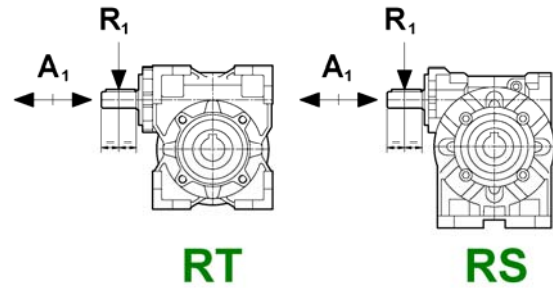

Input radial (overhung) loads R_1 [daN]

$$A_1 = 0,2 \times R_1$$

min ⁻¹	2800	1400	900	700	500	300
RS-RT 28	5	7	8	9	10	12
RS-RT 40	11	15	16	17	18	20
RS-RT 50	15	20	22	25	28	30
RS-RT 60	23	30	33	35	37	40
RS-RT 70	26	35	40	44	47	50
RS-RT 85	34	45	52	58	62	70
RS-RT 110	57	75	80	85	92	100
RS130	70	100	105	110	115	120
RS150	90	120	125	130	140	150

Gear boxes Series RS and RT

Output external loads

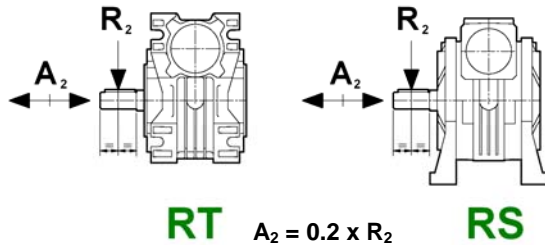

Output radial (overhung) loads R_2 [daN] with standard bearings

min ⁻¹	280	200	140	93	70	50	35	29	25	20	18	14	Nr. rodam.
RS-RT 28	---	45	50	55	60	62	70	75	80	90	95	100	16005
RS-RT 40	100	100	110	120	135	150	160	170	180	190	200	230	16006
RS-RT 50	145	125	145	170	190	200	230	240	260	280	290	320	16008
RS-RT 60	225	240	250	290	330	360	390	430	320	500	420	560	①
RS-RT 70	260	270	290	360	390	420	450	520	550	590	630	670	②
RS-RT 85	330	330	370	440	470	540	550	630	660	710	750	830	③
RS-RT 110	---	390	415	520	540	590	570	750	780	800	880	980	④
RS 130	---	500	565	615	650	660	780	880	950	970	1050	1150	6015
RS 150	---	650	770	830	880	900	1100	1200	1250	1300	1400	1500	6216

① - RS: 6008 / RT: 6208

③ - RS: 6010 / RT: 6210

② - RS: 6009 / RT: 6209

④ - RS: 6012 / RT: 6212

Output radial (overhung) loads R_2 [daN] with heavy duty bearings

min ⁻¹	280	200	140	93	70	50	35	29	25	20	18	14	Nr. rodam.
RS-RT 28	---	65	75	82	90	93	105	112	120	130	130	130	6005
RS-RT 40	140	150	155	165	190	210	225	240	250	260	260	260	32006
RS-RT 50	200	175	200	240	260	300	340	360	390	420	420	420	32008
RS-RT 60	290	300	320	370	420	480	510	570	610	660	660	660	30208
RS-RT 70	335	330	370	450	516	560	610	690	730	790	790	790	⑤
RS-RT 85	410	420	460	550	630	720	730	840	870	940	940	940	⑥
RS-RT 110	---	500	540	670	750	800	930	1050	1110	1110	1110	1110	⑦
RS 130	---	700	790	860	970	990	1170	1290	1420	1450	1450	1450	32015
RS 150	---	900	1080	1160	1320	1350	1650	1800	1870	1950	1950	1950	30216

⑤ - RS: 32009 / RT: 30209

⑥ - RS: 32010 / RT: 30210

⑦ - RS: 32012 / RT: 30212

Gear boxes Series RS and RT

FRS - FRT

Motor Frames

FRS FRT	min ⁻¹ IEC	i = 5	i7	10	15	20	28	40	49	56	70	80	100
		280	200	140	93	70	50	35	29	25	20	18	14
28	56	---	⊙	⊙	⊙	⊙	⊙	⊙	⊙	⊙	⊙	⊙	⊙
	63	---	⊙	⊙	⊙	⊙	⊙	⊙	⊙	⊙	⊙	⊙	⊙
40	56	⊙	⊙	⊙	⊙	⊙	⊙	⊙	⊙	⊙	⊙	⊙	⊙
	63	⊙	⊙	⊙	⊙	⊙	⊙	⊙	⊙	⊙	⊙	⊙	⊙
	71	⊙	⊙	⊙	⊙	⊙	⊙	⊙	⊙	⊙	⊙	⊙	⊙
50	63	⊙	⊙	⊙	⊙	⊙	⊙	⊙	⊙	⊙	⊙	⊙	⊙
	71	⊙	⊙	⊙	⊙	⊙	⊙	⊙	⊙	⊙	⊙	⊙	⊙
	80	⊙	⊙	⊙	⊙	⊙	⊙	⊙	⊙	⊙	⊙	⊙	⊙
60	71	⊙	⊙	⊙	⊙	⊙	⊙	⊙	⊙	⊙	⊙	⊙	⊙
	80	⊙	⊙	⊙	⊙	⊙	⊙	⊙	⊙	⊙	⊙	⊙	⊙
	90	⊙	⊙	⊙	⊙	⊙	⊙	⊙	⊙	⊙	⊙	⊙	⊙
70	71	⊙	⊙	⊙	⊙	⊙	⊙	⊙	⊙	⊙	⊙	⊙	⊙
	80	⊙	⊙	⊙	⊙	⊙	⊙	⊙	⊙	⊙	⊙	⊙	⊙
	90	⊙	⊙	⊙	⊙	⊙	⊙	⊙	⊙	⊙	⊙	⊙	⊙
	100	⊙	⊙	⊙	⊙	⊙	⊙	⊙	⊙	⊙	⊙	⊙	⊙
85	80	⊙	⊙	⊙	⊙	⊙	⊙	⊙	⊙	⊙	⊙	⊙	⊙
	90	⊙	⊙	⊙	⊙	⊙	⊙	⊙	⊙	⊙	⊙	⊙	⊙
	100/112	⊙	⊙	⊙	⊙	⊙	⊙	⊙	⊙	⊙	⊙	⊙	⊙
110	90	---	⊙	⊙	⊙	⊙	⊙	⊙	⊙	⊙	⊙	⊙	⊙
	100/112	---	⊙	⊙	⊙	⊙	⊙	⊙	⊙	⊙	⊙	⊙	⊙
	132	---	○	○	○	○	○	○	○	○	○	○	○
*130	100/112	---	○	○	○	○	○	○	○	○	○	○	○
	132	---	○	○	○	○	○	○	---	---	---	---	---
*150	100/112	---	○	○	○	○	○	○	○	○	○	○	○
	132	---	○	○	○	○	○	○	○	○	○	---	---
	160	---	○	○	○	○	○	○	○	---	---	---	---

* only RS

- ⊙ - B5 & B14 (Elastic coupling G input)
- ⊙ - B5 (Elastic coupling G input)
- - B5 & B14 (Quill IEC input)
- - B5 (Quill IEC input)

FRA - FTA

Gear boxes Series RS and RT

Motor Frames

FRA	IEC	i = 7	10	15	20	28	40	49	56	70	80	100
63/40	56 B5&B14	①	①	①	①	①	①	①	①	①	①	①
63/50		①	①	①	①	①	①	①	①	①	①	①
63/60		---	---	---	---	①	①	①	①	①	①	①
63/40	63 B5&B14	①	①	①	①	①	①	①	①	①	①	①
63/50		①	①	①	①	①	①	①	①	①	①	①
63/60		---	---	---	---	①	①	①	①	①	①	①
71/50	71 B5&B14	②	②	②	②	②	②	②	---	---	---	---
71/60		②	②	②	②	②	②	②	②	②	②	②
71/70		②	②	②	②	②	②	②	②	②	②	②
71/85		---	---	---	---	---	②	②	②	②	②	②
80/60	80 B5&B14	③	③	③	③	③	---	---	---	---	---	---
80/70		③	③	③	③	③	③	③	---	---	---	---
80/85		③	③	③	③	③	③	③	③	③	③	③
80/110		④	④	④	④	③	③	③	③	③	③	③
80/60	90 B5&B14	③	③	③	③	③	---	---	---	---	---	---
80/70		③	③	③	③	③	③	③	---	---	---	---
80/85		③	③	③	③	③	③	③	③	③	③	③
80/110		④	④	④	④	③	③	③	③	③	③	③
*100/110		④	④	④	④	③	③	③	③	③	③	③
*100/130	90 B5	⑤	⑤	⑤	⑤	⑤	⑤	⑤	⑤	⑤	⑤	⑤
	100 B5	⑤	⑤	⑤	⑤	⑤	⑤	⑤	⑤	⑤	⑤	⑤
*100/150	90 B5	⑥	⑥	⑥	⑤	⑤	⑤	⑤	⑤	⑤	⑤	⑤
	100 B5	⑥	⑥	⑥	⑤	⑤	⑤	⑤	⑤	⑤	⑤	⑤

* only RS

* - Helical stage input

** - Helical stage output & FRS-FRT input

① - $\varnothing 105 \times 14$

② - $\varnothing 120 \times 19$

③ - $\varnothing 140 \times 24$

④ - $\varnothing 140 \times 28$

⑤ - $\varnothing 200 \times 28$

⑥ - $\varnothing 200 \times 28$ (Wormshaft bore $\varnothing 38$ mm + Bush $\varnothing 38/\varnothing 28$)

Gear boxes Series RS and RT

2800 min⁻¹

Selection Table

Single worm gear boxes RS - RT

RS RT	i =	5	7	10	15	20	28	40	49	56	70	80	100
	min ⁻¹	560	400	280	187	140	100	70	57	50	40	35	28
28	kW	---	0.63	0.49	0.35	0.25	0.23	0.16	0.13	0.12	0.09	0.08	0.04
	Nm	---	13	14	14	13	15	14	13	12	11	10	7
	eff.	---	0.86	0.83	0.79	0.77	0.69	0.64	0.61	0.54	0.49	0.49	0.46
40	kW	2.1	1,5	1,2	0,82	0,56	0,49	0,36	0,30	0,26	0,21	0,19	0,15
	Nm	32	31	34	34	30	34	32	31	30	29	28	26
	eff.	0.89	0,87	0,85	0,81	0,78	0,72	0,66	0,62	0,6	0,57	0,54	0,51
50	kW	3.8	3,0	2,0	1,5	0,95	0,92	0,63	0,51	0,43	0,33	0,31	0,23
	Nm	58	62	59	61	52	66	59	56	53	46	49	40
	eff.	0.90	0,88	0,86	0,82	0,8	0,75	0,69	0,66	0,64	0,58	0,58	0,52
60	kW	5.8	4,4	3,5	2,6	1,9	1,6	1,1	0,72	0,73	0,60	0,52	0,34
	Nm	90	93	104	110	108	116	105	85	92	92	85	68
	eff.	0.90	0,88	0,87	0,84	0,82	0,76	0,73	0,71	0,66	0,64	0,6	0,58
70	kW	8.1	5,7	4,3	3,2	2,4	2,2	1,5	1,2	1,0	0,80	0,69	0,54
	Nm	126	122	130	139	136	161	155	142	130	120	115	107
	eff.	0.91	0,89	0,88	0,85	0,83	0,78	0,74	0,7	0,68	0,63	0,61	0,58
85	kW	13.0	9,6	7,5	5,3	4,3	3,1	2,4	2,0	1,7	1,3	1,1	0,93
	Nm	202	205	225	234	237	235	250	242	229	210	200	190
	eff.	0.91	0,89	0,88	0,86	0,8	0,8	0,76	0,72	0,71	0,67	0,64	0,6
110	kW	---	17,5	14,8	10,7	8,6	7,0	5,0	4,5	3,6	3,1	3,0	2,1
	Nm	---	375	445	470	490	530	520	545	490	525	540	450
	eff.	---	0,9	0,88	0,86	0,84	0,79	0,76	0,73	0,71	0,7	0,67	0,62
*130	kW	---	26.3	21.6	15.8	12.2	9.4	7.7	6.0	5.3	3.9	3.3	2.4
	Nm	---	565	655	705	715	715	815	740	780	670	620	560
	eff.	---	0.9	0.89	0.87	0.86	0.8	0.78	0.74	0.77	0.72	0.68	0.68
*150	kW	---	37.0	29.6	22.8	17.1	13.6	10.7	8.5	6.6	5.5	4.9	3.6
	Nm	---	795	900	1015	1005	1065	1170	1090	970	950	915	845
	eff.	---	0.9	0.89	0.87	0.86	0.82	0.8	0.77	0.77	0.72	0.68	0.68

* only RS

1400 min⁻¹

Gear boxes Series RS and RT

Single worm gear boxes RS - RT

Selection Table

RS RT	i =	5	7	10	15	20	28	40	49	56	70	80	100
	min ⁻¹	280	200	140	93	70	50	35	29	25	20	18	14
28	kW	---	0,45	0,33	0,23	0,16	0,16	0,10	0,09	0,08	0,06	0,05	0,03
	Nm	---	18	18	18	16	20	17	17	15	12	12	8
	eff.	---	0.84	0.81	0.77	0.74	0.66	0.62	0.57	0.51	0.45	0.45	0.43
40	kW	1.5	1,1	0,81	0,55	0,38	0,37	0,25	0,21	0,18	0,14	0,12	0,09
	Nm	45	45	46	44	39	48	42	41	38	36	32	29
	eff.	0.87	0.85	0.83	0.78	0.75	0.68	0.61	0.58	0.56	0.52	0.50	0.46
50	kW	2.7	1,8	1,3	0,93	0,63	0,63	0,41	0,37	0,31	0,25	0,20	0,13
	Nm	81	75	75	74	65	85	72	76	71	63	58	43
	eff.	0.88	0.86	0.84	0.78	0.76	0.71	0.64	0.62	0.60	0.53	0.52	0.47
60	kW	4.1	2,8	2,3	1,6	1,2	1,0	0,75	0,62	0,54	0,46	0,37	0,25
	Nm	125	113	133	130	122	139	135	128	123	122	106	83
	eff.	0.89	0.86	0.84	0.81	0.77	0.71	0.66	0.62	0.60	0.55	0.53	0.49
70	kW	5.7	4,0	3,1	2,2	1,8	1,5	1,2	0,84	0,74	0,58	0,50	0,37
	Nm	176	166	180	188	194	216	238	189	180	163	154	130
	eff.	0.89	0.88	0.86	0.83	0.81	0.75	0.71	0.67	0.64	0.59	0.56	0.52
85	kW	9.1	6,2	4,6	3,4	2,9	2,2	2,0	1,4	1,2	0,96	0,86	0,55
	Nm	279	259	268	289	322	319	401	316	305	290	280	210
	eff.	0.90	0.88	0.86	0.83	0.82	0.76	0.72	0.67	0.68	0.63	0.60	0.56
110	kW	---	12,5	9,0	6,5	5,7	4,4	3,5	2,7	2,2	2,0	1,5	1,1
	Nm	---	525	532	560	647	642	691	631	595	635	525	469
	eff.	---	0.88	0.87	0.84	0.83	0.76	0.73	0.71	0.70	0.67	0.66	0.61
*130	kW	---	19.0	15.0	11.0	8,5	7,5	5,5	3,9	3,7	2,7	2,4	1,8
	Nm	---	807	890	960	975	1100	1140	950	1005	865	810	750
	eff.	---	0.89	0.87	0.85	0.84	0.77	0.76	0.72	0.71	0.67	0.63	0.61
*150	kW	---	24.9	21.0	16.0	12,5	9,5	8,0	5,9	5,1	3,8	3,3	2,6
	Nm	---	1060	1260	1410	1430	1435	1680	1440	1420	1230	1170	1120
	eff.	---	0.89	0.88	0.86	0.84	0.79	0.77	0.73	0.73	0.68	0.65	0.63

* only RS

Gear boxes Series RS and RT

900 min⁻¹

Selection Table

Single worm gear boxes RS - RT

RS RT	i =	5	7	10	15	20	28	40	49	56	70	80	100
	min ⁻¹	180	128	90	60	45	32	23	19	16	13	11	9
28	kW	---	0,36	0,24	0,18	0,13	0,12	0,08	0,07	0,06	0,04	0,03	0,02
	Nm	---	22	20	21	19	22	20	19	16	13	11	8
	eff.	---	0.82	0.78	0.72	0.70	0.61	0.56	0.52	0.45	0.43	0.40	0.37
40	kW	1.2	0,84	0,64	0,44	0,30	0,28	0,19	0,16	0,14	0,12	0,10	0,08
	Nm	54	52	54	52	45	52	46	43	41	40	39	36
	eff.	0.86	0.83	0.80	0.74	0.70	0.63	0.56	0.52	0.49	0.46	0.44	0.42
50	kW	2.1	1,5	1,1	0,75	0,52	0,51	0,35	0,28	0,25	0,19	0,17	0,12
	Nm	96	95	95	91	79	99	85	81	80	67	67	55
	eff.	0.86	0.85	0.81	0.76	0.72	0.65	0.58	0.56	0.54	0.47	0.46	0.42
60	kW	3.2	2,4	1,9	1,4	1,0	0,87	0,56	0,43	0,40	0,32	0,28	0,19
	Nm	150	150	163	166	161	175	152	135	130	125	115	94
	eff.	0.87	0.85	0.83	0.75	0.76	0.68	0.64	0.61	0.55	0.53	0.480	0.47
70	kW	4.5	3,2	2,4	1,7	1,3	1,2	0,87	0,64	0,53	0,42	0,38	0,30
	Nm	212	202	211	218	207	242	240	205	187	170	160	147
	eff.	0.88	0.86	0.83	0.79	0.77	0.70	0.654	0.62	0.59	0.54	0.50	0.46
85	kW	7.2	5,0	3,9	3,0	2,1	1,8	1,5	1,0	0,83	0,73	0,64	0,51
	Nm	338	320	350	378	355	373	410	350	332	300	290	260
	eff.	0.88	0.86	0.84	0.80	0.78	0.71	0.66	0.672	0.671	0.55	0.53	0.48
110	kW	---	9,8	8,0	5,7	4,4	3,7	2,7	2,3	1,9	1,7	1,5	0,94
	Nm	---	635	720	745	745	795	780	780	690	765	715	500
	eff.	---	0.87	0.85	0.82	0.79	0.73	0.68	0.64	0.62	0.59	0.57	0.50
*130	kW	---	14,9	11,7	8,4	6,5	5,1	4,1	3,1	2,8	2,1	1,8	1,3
	Nm	---	975	1070	1115	1115	1145	1215	1095	1145	960	890	805
	eff.	---	0.88	0.86	0.83	0.81	0.75	0.70	0.67	0.68	0.63	0.58	0.57
*150	kW	---	20,8	15,9	12,2	9,3	7,3	5,6	4,5	3,3	2,9	2,5	2,0
	Nm	---	1360	1470	1635	1625	1660	1740	1600	1370	1390	1290	1230
	eff.	---	0.88	0.87	0.84	0.82	0.77	0.73	0.69	0.69	0.64	0.61	0.58

* only RS

700 min⁻¹

Gear boxes Series RS and RT

Single worm gear boxes RS - RT

Selection Table

RS RT	i =	5	7	10	15	20	28	40	49	56	70	80	100
	min ⁻¹	140	100	70	47	35	25	18	15	13	10	8.7	7
28	kW	---	0,29	0,21	0,14	0,10	0,10	0,06	0,05	0,04	0,03	0,02	0,01
	Nm	---	23	23	22	21	24	21	20	17	13	11	8
	eff.	---	0.81	0.77	0.71	0.69	0.60	0.55	0.51	0.44	0.40	0.39	0.36
40	kW	1.00	0,74	0,54	0,39	0,26	0,24	0,17	0,14	0,12	0,10	0,09	0,07
	Nm	59	58	58	58	49	55	49	46	45	43	41	38
	eff.	0.85	0.82	0.79	0.73	0.68	0.59	0.53	0.50	0.48	0.44	0.42	0.39
50	kW	1.8	1,4	0,92	0,65	0,44	0,43	0,29	0,24	0,21	0,16	0,15	0,12
	Nm	106	110	100	99	86	106	91	87	83	70	72	62
	eff.	0.86	0.83	0.80	0.75	0.71	0.64	0.57	0.542	0.52	0.45	0.44	0.39
60	kW	2.8	2,0	1,6	1,1	0,87	0,73	0,49	0,35	0,34	0,26	0,24	0,17
	Nm	165	164	177	178	175	187	165	140	139	128	120	100
	eff.	0.87	0.84	0.81	0.77	0.74	0.67	0.62	0.59	0.54	0.51	0.46	0.44
70	kW	3.9	2,7	2,1	1,4	1,1	1,0	0,71	0,55	0,46	0,36	0,32	0,24
	Nm	234	216	233	231	225	256	245	220	197	176	167	150
	eff.	0.87	0.85	0.82	0.78	0.75	0.68	0.63	0.60	0.56	0.51	0.48	0.45
85	kW	6.2	4,6	3,5	2,5	1,9	1,5	1,2	0,93	0,78	0,59	0,56	0,44
	Nm	372	370	400	408	388	400	420	379	353	310	305	275
	eff.	0.87	0.85	0.83	0.79	0.76	0.69	0.65	0.61	0.59	0.55	0.50	0.46
110	kW	---	8,5	6,8	4,9	3,9	3,3	2,3	2,0	1,7	1,5	1,2	0,79
	Nm	---	700	780	795	815	890	820	840	770	815	720	515
	eff.	---	0.86	0.84	0.80	0.77	0.71	0.66	0.62	0.60	0.57	0.55	0.48
*130	kW	---	12,8	10,3	7,4	5,6	4,4	3,6	2,7	2,4	1,8	1,6	1,1
	Nm	---	1060	1200	1230	1215	1200	1320	1185	1215	1030	955	855
	eff.	---	0.87	0.85	0.81	0.80	0.72	0.68	0.65	0.66	0.61	0.56	0.55
*150	kW	---	18,0	13,7	10,6	8,1	6,2	4,9	3,8	3,0	2,6	2,3	1,7
	Nm	---	1475	1610	1805	1780	1790	1890	1710	1535	1500	1425	1275
	eff.	---	0.87	0.86	0.83	0.81	0.75	0.71	0.68	0.67	0.61	0.58	0.56

* only RS

Gear boxes Series RS and RT

1400 min⁻¹

Selection Table

Helical worm gear boxes RA - TA

	$i_1 =$	3.5	6.3	8									
	min ⁻¹	400	225	175									
XA63	kW	0.50	0.23	0.18									
	Nm	12	10	9									
	R ₂ [N]	390	450	450									
XA71	kW	1.1	0.52	0.37									
	Nm	26	22	20									
	R ₂ [N]	490	560	560									
XA80	kW	3.1	1.5	1.1									
	Nm	68	65	60									
	R ₂ [N]	610	700	700									
XA100	kW	8.7	4.0	2.2									
	Nm	235	163	136									
	R ₂ [N]	1500	2500	2500									
$i_1 = 3.5$	$i = i_1 \times i_2$	25	35	53	70	98	140	172	196	245	280	350	
	min ⁻¹	57	40	27	20	14	10	8	7	6	5	4	
	i_2	7	10	15	20	28	40	49	56	70	80	100	
63/40	kW	0.55	0.40	0.28	0.20	0.19	0.13	0.11	0.10	0.06	0.05	0.03	
	Nm	72	72	70	60	70	64	58	56	42	35	25	
	eff.	0.78	0.75	0.70	0.63	0.56	0.50	0.46	0.44	0.41	0.40	0.35	
63/50	kW	1.02	0.70	0.50	0.33	0.32	0.21	0.20	0.16	0.11	0.09	0.06	
	Nm	135	127	125	105	125	105	115	100	80	70	50	
	eff.	0.79	0.76	0.70	0.66	0.59	0.52	0.50	0.46	0.42	0.40	0.35	
63/60	kW	1.53	1.18	0.83	0.57	0.53	0.33	0.27	0.23	0.19	0.15	0.10	
	Nm	205	217	215	192	217	177	170	152	145	110	85	
	eff.	0.80	0.77	0.72	0.70	0.61	0.57	0.54	0.49	0.45	0.38	0.36	
71/70	kW	1.96	1.48	1.08	0.77	0.72	0.50	0.43	0.36	0.30	0.26	0.19	
	Nm	265	275	285	260	310	270	270	235	225	200	180	
	eff.	0.81	0.78	0.74	0.71	0.64	0.57	0.54	0.49	0.45	0.41	0.39	
71/85	kW	3.14	2.39	1.77	1.37	1.11	0.80	0.65	0.58	0.49	0.40	0.26	
	Nm	430	450	475	470	475	445	420	410	390	340	250	
	eff.	0.82	0.79	0.75	0.72	0.64	0.58	0.55	0.53	0.48	0.44	0.40	
80/110	kW	6.02	4.63	3.58	2.61	2.18	1.60	1.27	1.12	0.86	0.86	0.54	
	Nm	835	895	950	910	960	950	850	820	750	740	540	
	eff.	0.83	0.81	0.74	0.73	0.66	0.62	0.57	0.55	0.52	0.45	0.42	
RA 100/130	kW	7.0	6.8	5.5	3.8	3.1	2.3	1.7	1.5	1.3	1.1	0.8	
	Nm	975	1320	1495	1350	1430	1380	1300	1250	1200	1080	880	
	eff.	0.83	0.81	0.77	0.75	0.67	0.63	0.64	0.62	0.60	0.50	0.48	
RA 100/150	kW	7.9	7.8	7.5	5.7	4.5	3.3	2.7	2.4	1.8	1.6	1.0	
	Nm	1115	1535	2090	2060	2130	2050	2040	2025	1700	1459	1200	
	eff.	0.84	0.82	0.79	0.76	0.69	0.66	0.64	0.62	0.60	0.52	0.50	

1400 min⁻¹

Gear boxes Series RS and RT

Helical worm gear boxes RA - TA

Selection Table

i₁ = 6.3	i = i₁ x i₂	44	63	95	126	176	252	309	353	441	504	630
	min⁻¹	32	22	15	11	8	5.5	4.6	4	3.2	2.8	2.2
	i₂	7	10	15	20	28	40	49	56	70	80	100
63/40	kW	0.35	0.25	0.17	0.12	0.11	0.08	0.06	0.06	0.05	0.04	0.03
	Nm	79	78	74	63	69	63	57	55	53	51	46
	eff.	0.76	0.72	0.67	0.60	0.52	0.45	0.43	0.39	0.35	0.34	0.31
63/50	kW	0.62	0.42	0.30	0.20	0.20	0.14	0.11	0.10	0.09	0.07	0.05
	71/50 Nm	145	133	130	113	138	115	108	100	92	89	72
	eff.	0.78	0.74	0.67	0.63	0.55	0.48	0.45	0.42	0.36	0.36	0.31
63/60	kW	0.92	0.74	0.52	0.40	0.35	0.23	0.16	0.16	0.11	0.10	0.08
	71/60 Nm	218	237	235	230	238	210	160	175	141	130	122
	80/60 eff.	0.79	0.75	0.70	0.67	0.57	0.53	0.49	0.45	0.42	0.37	0.35
71/70	kW	1.2	0.95	0.68	0.50	0.44	0.32	0.26	0.23	0.18	0.17	0.12
	80/70 Nm	289	310	310	292	320	295	272	254	221	210	190
	eff.	0.80	0.76	0.71	0.68	0.60	0.54	0.50	0.46	0.42	0.37	0.36
71/85	kW	2.0	1.6	1.1	0.84	0.69	0.53	0.43	0.37	0.28	0.26	0.22
	80/85 Nm	490	526	516	495	501	500	466	449	391	380	345
	eff.	0.80	0.77	0.72	0.69	0.60	0.55	0.51	0.50	0.46	0.42	0.36
80/110	kW	4.3	3.2	2.4	1.8	1.6	1.1	1.0	0.80	0.66	0.51	0.32
	100/110 Nm	1030	1100	1150	100	1170	1110	1100	995	950	780	550
	eff.	0.81	0.79	0.74	0.71	0.63	0.57	0.53	0.52	0.48	0.45	0.39
100/130	kW	6.41	4.94	3.72	2.71	2.37	1.65	1.47	1.25	1.02	0.82	0.47
	Nm	1600	1700	1800	1700	1800	1700	1700	1600	1600	1300	900
	eff.	0.83	0.80	0.75	0.73	0.63	0.60	0.55	0.53	0.52	0.46	0.45
100/150	kW	8.41	6.61	5.04	3.77	3.02	2.31	1.82	1.41	1.24	1.09	0.84
	Nm	2100	2300	2500	2400	2400	2500	2300	2000	1800	1800	1700
	eff.	0.83	0.81	0.77	0.74	0.66	0.63	0.60	0.59	0.81	0.48	0.47

Gear boxes Series RS and RT

1400 min⁻¹

Selection Table

Helical worm gear boxes RA - TA

$i_1 = 8$	$i = i_1 \times i_2$	56	80	120	160	224	320	392	448	560	640	800
	min ⁻¹	25	18	12	9	6	4	3.5	3	2.5	2.2	1.75
	i_2	7	10	15	20	28	40	49	56	70	80	100
63/40	kW	0.32	0.23	0.16	0.11	0.11	0.08	0.06	0.05	0.03	0.03	0.02
	Nm	93	89	84	72	85	75	69	59	45	38	27
	eff.	0.75	0.72	0.65	0.59	0.50	0.44	0.41	0.38	0.36	0.34	0.31
63/50	kW	0.58	0.41	0.28	0.20	0.18	0.13	0.10	0.09	0.06	0.05	0.03
	Nm	170	165	154	130	150	130	120	115	86	73	53
	eff.	0.77	0.73	0.67	0.61	0.55	0.47	0.45	0.41	0.36	0.37	0.31
63/60	kW	0.87	0.68	0.49	0.34	0.31	0.21	0.16	0.15	0.10	0.08	0.05
	Nm	260	280	275	240	270	235	220	200	155	125	92
	eff.	0.78	0.75	0.69	0.65	0.57	0.51	0.50	0.43	0.41	0.37	0.35
71/70	kW	1.26	0.88	0.63	0.44	0.48	0.28	0.24	0.20	0.16	0.12	0.05
	Nm	380	365	360	325	440	320	320	275	245	200	145
	eff.	0.79	0.76	0.70	0.67	0.60	0.53	0.50	0.45	0.41	0.38	0.35
71/85	kW	1.76	1.42	1.07	0.85	0.65	0.48	0.40	0.33	0.26	0.20	0.13
	Nm	530	595	620	620	600	560	550	510	450	360	260
	eff.	0.79	0.77	0.71	0.67	0.60	0.54	0.52	0.50	0.45	0.41	0.37
80/110	kW	3.42	2.75	1.97	1.52	1.29	0.97	0.73	0.64	0.52	0.43	0.27
	Nm	1045	1170	1180	1160	1200	1180	1020	980	920	850	550
	eff.	0.80	0.78	0.73	0.70	0.61	0.56	0.52	0.50	0.46	0.45	0.38
RA 100/130	kW	3.3	3.0	3.2	2.3	1.8	1.2	1.1	0.9	0.7	0.7	0.5
	Nm	1000	1240	1840	1765	1760	1700	1660	1600	1435	1330	1160
	eff.	0.80	0.78	0.73	0.72	0.62	0.58	0.56	0.54	0.51	0.45	0.43
RA 100/150	kW	3.7	3.4	3.6	3.4	2.7	2.0	1.7	1.4	1.1	1.0	0.8
	Nm	1130	1425	2150	2580	2675	2860	2550	2490	2110	1970	1855
	eff.	0.81	0.79	0.75	0.72	0.63	0.61	0.56	0.57	0.49	0.46	0.45

1400 min⁻¹

Gear boxes Series RS and RT

Two stage worm gear boxes RS/RS - RT/RT

Selection Table

RS/RS RT/RT	$i = i_1 \times i_2$	420	560	784	1120	1568	2240	2800	4000	5600	8000	10000
	min ⁻¹	3.3	2.5	1.8	1.25	0.9	0.6	0.5	0.35	0.25	0.17	0.14
	$i_1 =$ $i_2 =$	15 28	20 28	28 28	40 28	56 28	56 40	70 40	100 40	100 56	100 80	100 100
28/28	W	32	25	21	16	13	9	8	6	3	1.8	1.3
	Nm	35	36	36	36	35	30	30	30	16	12	11
	eff.	0.38	0.37	0.32	0.30	0.25	0.21	0.20	0.18	0.14	0.12	0.13
28/40	W	75	60	46	34	30	22	22	14	11	5	3
	Nm	85	85	80	80	80	73	76	70	62	41	25
	eff.	0.39	0.37	0.33	0.31	0.25	0.21	0.18	0.18	0.15	0.14	0.12
28/50	W	133	106	91	74	60	36	36	28	20	10	6
	Nm	150	150	160	175	160	125	131	147	125	78	49
	eff.	0.39	0.37	0.33	0.31	0.25	0.22	0.19	0.19	0.16	0.14	0.12
28/60	W	197	157	132	91	91	67	54	30	32	16	10
	Nm	240	240	245	230	260	245	217	164	195	128	91
	eff.	0.42	0.40	0.35	0.33	0.27	0.23	0.21	0.20	0.16	0.14	0.13
40/70	W	298	249	198	157	119	86	72	60	42	24	16
	Nm	380	400	400	395	380	370	345	360	321	201	154
	eff.	0.44	0.42	0.38	0.33	0.30	0.27	0.25	0.22	0.20	0.15	0.14
40/85	W	447	372	276	224	180	138	120	90	72	39	26
	Nm	595	625	585	625	610	615	595	565	550	373	264
	eff.	0.46	0.44	0.40	0.35	0.32	0.28	0.26	0.23	0.20	0.17	0.15
50/110	W	865	756	579	453	382	292	235	163	128	82	51
	Nm	1190	1300	1300	1280	1350	1340	1210	1070	980	810	560
	eff.	0.48	0.45	0.42	0.37	0.33	0.30	0.27	0.24	0.20	0.18	0.16
RS/RS 60/130	kW	1.5	1.1	0.75	0.55	0.55	0.37	0.25	0.25	0.25	0.25	0.25
	Nm	2015	1930	1670	1530	2015	1830	1410	1770	1850	1420	1225
	eff.	0.50	0.46	0.43	0.40	0.35	0.33	0.30	0.27	0.25	0.21	0.20
RS/RS 70/150	kW	1.8	1.5	1.1	0.75	0.75	0.55	0.37	0.37	0.25	0.25	0.25
	Nm	2570	2830	2570	2460	2850	3020	2325	2875	2670	2135	1995
	eff.	0.52	0.50	0.46	0.43	0.39	0.36	0.33	0.31	0.27	0.23	0.22

Gear boxes Series RS and RT

1400 min⁻¹

Selection Table

Geared motors

0.06 kW						0.09 kW					
	min ⁻¹	i =	Nm	SF	kg		min ⁻¹	i =	Nm	SF	kg
MRS-MRT 28	200	7	2.4	>3	3.6	MRS-MRT 40/85	0.4	4000	565	1.0	19
MRS-MRT 28	140	10	3.3	>3	3.6	MRS-MRT 40/85	0.3	5600	688	0.8	19
MRS-MRT 28	93	15	4.7	>3	3.6	0.12 kW					
MRS-MRT 28	70	20	6.1	2.6	3.6		min ⁻¹	i =	Nm	SF	kg
MRS-MRT 28	50	28	7.6	2.6	3.6	MRS-MRT 28	200	7	4.8	>3	4.8
MRS-MRT 28	35	40	10	1.7	3.6	MRS-MRT 28	140	10	6.6	2.7	4.8
MRA-MTA 63/40	32	44	14	>3	6.5	MRS-MRT 28	93	15	9.5	1.9	4.8
MRS-MRT 28	29	49	11	1.5	3.6	MRS-MRT 28	70	20	12	1.3	4.8
MRS-MRT 28	25	56	12	1.3	3.6	MRS-MRT 28	50	28	15	1.3	4.8
MRA-MTA 63/40	22	63	19	>3	6.5	MRS-MRT 40	35	40	20	2.1	6.2
MRS-MRT 28	20	70	13	0.9	3.6	MRA-MTA 63/40	32	44	27	2.9	7.7
MRS-MRT 40	18	80	16	2.0	5.0	MRS-MRT 40	29	49	23	1.8	6.2
MRA-MTA 63/40	15	95	26	2.8	6.5	MRS-MRT 40	25	56	26	1.5	6.2
MRS-MRT 40	14	100	19	1.5	5.0	MRA-MTA 63/40	22	63	37	2.1	7.7
MRA-MTA 63/40	11	126	31	2.0	6.5	MRS-MRT 40	20	70	30	1.2	6.2
MRS-MRT 28/28	9.3	150	31	1.1	5.0	MRS-MRT 40	18	80	33	1.0	6.2
MRA-MTA 63/40	8.0	176	37	1.8	6.5	MRA-MTA 63/40	15	95	52	1.4	7.7
MRS-MRT 28/28	7.0	200	30	0.8	5.0	MRS-MRT 50	14	100	38	1.1	7.5
MRA-MTA 63/40	5.5	252	46	1.4	6.5	MRA-MTA 63/40	11	126	62	1.0	7.7
MRS-MRT 28/28	5.0	280	35	0.8	5.0	MRS-MRT 28/40	9.3	150	64	1.4	7.6
MRA-MTA 63/40	4.6	309	54	1.0	6.5	MRA-MTA 63/40	8.0	176	75	0.9	7.7
MRA-MTA 63/40	4.0	353	56	1.0	6.5	MRS-MRT 28/40	7.0	200	77	1.0	7.6
MRS-MRT 28/40	3.3	420	67	1.3	6.4	MRA-MTA 63/50	5.5	252	99	1.2	9.0
MRA-MTA 63/50	3.2	441	65	1.4	7.8	MRS-MRT 28/40	5.0	280	94	0.8	7.6
MRA-MTA 63/50	2.8	504	74	1.2	7.8	MRA-MTA 63/50	4.6	309	114	0.9	9.0
MRS-MRT 28/40	2.5	560	85	1.0	6.4	MRS-MRT 28/50	3.3	420	134	1.2	8.9
MRA-MTA 63/50	2.2	630	80	0.9	7.8	MRS-MRT 28/50	2.5	560	170	0.9	8.9
MRS-MRT 28/50	1.8	784	106	1.5	7.7	MRS-MRT 28/60	1.8	784	225	1.1	12
MRS-MRT 28/50	1.3	1120	142	1.2	7.7	MRS-MRT 28/60	1.3	1120	303	0.8	12
MRS-MRT 28/50	0.9	1568	160	1.0	7.7	MRS-MRT 40/70	0.9	1568	385	1.0	16
MRS-MRT 28/60	0.6	2240	211	1.2	10	MRS-MRT 40/85	0.6	2240	513	1.2	20
MRS-MRT 28/60	0.5	2800	241	0.9	10	MRS-MRT 40/85	0.5	2800	596	1.0	20
MRS-MRT 40/70	0.4	4000	360	1.0	15	MRS-MRT 40/85	0.4	4000	753	0.8	20
MRS-MRT 40/70	0.3	5600	458	0.7	15	0.18 kW					
MRS-MRT 40/85	0.2	8000	557	0.7	19		min ⁻¹	i =	Nm	SF	kg
MRS-MRT 40/110	0.1	10000	614	0.4	19	MRS-MRT 28	200	7	7.2	2.5	5.4
0.09 kW						MRS-MRT 28	140	10	9.9	1.8	5.4
	min ⁻¹	i =	Nm	SF	kg	MRS-MRT 28	93	15	14	1.3	5.4
MRS-MRT 28	200	7	3.6	>3	3.7	MRS-MRT 40	70	20	18	2.1	6.8
MRS-MRT 28	140	10	5.0	>3	3.7	MRS-MRT 40	50	28	23	2.1	6.8
MRS-MRT 28	93	15	7.1	2.5	3.7	MRS-MRT 40	35	40	30	1.4	6.8
MRS-MRT 28	70	20	9.1	1.8	3.7	MRA-MTA 63/40	32	44	41	1.9	8.3
MRS-MRT 28	50	28	11	1.8	3.7	MRS-MRT 40	29	49	35	1.2	6.8
MRS-MRT 28	35	40	15	1.1	3.7	MRS-MRT 40	25	56	39	1.0	6.8
MRA-MTA 63/40	32	44	21	>3	6.6	MRA-MTA 63/40	22	63	56	1.4	8.3
MRS-MRT 28	29	49	17	1.0	3.7	MRS-MRT 50	20	70	46	1.4	8.1
MRS-MRT 40	25	56	20	2.1	5.1	MRS-MRT 50	18	80	51	1.1	8.1
MRA-MTA 63/40	22	63	28	2.8	6.6	MRA-MTA 63/40	15	95	78	0.9	8.3
MRS-MRT 40	20	70	22	1.6	5.1	MRA-MTA 63/50	11	126	97	1.2	9.6
MRS-MRT 40	18	80	25	1.3	5.1	MRS-MRT 28/50	9.3	150	93	1.6	9.5
MRA-MTA 63/40	15	95	39	1.9	6.6	MRA-MTA 63/50	8.0	176	119	1.2	9.6
MRS-MRT 40	14	100	28	1.0	5.1	MRS-MRT 28/50	7.0	200	120	1.1	9.5
MRA-MTA 63/40	11	126	46	1.4	6.6	MRS-MRT 28/50	5.0	280	141	1.1	9.5
MRS-MRT 28/40	9.3	150	48	1.3	6.5	MRS-MRT 28/60	3.3	420	217	1.1	12
MRA-MTA 63/40	8.0	176	56	1.2	6.6	MRS-MRT 40/70	2.5	560	289	1.4	16
MRS-MRT 28/40	7.0	200	60	1.3	6.5	MRS-MRT 40/70	1.8	784	366	1.1	16
MRA-MTA 63/40	5.5	252	70	0.9	6.6	MRS-MRT 40/85	1.3	1120	481	1.3	21
MRS-MRT 28/40	5.0	280	70	1.0	6.5	MRS-MRT 40/85	0.9	1568	616	1.0	21
MRA-MTA 63/50	4.6	309	86	1.3	7.9	MRS-MRT 40/85	0.6	2240	770	0.8	21
MRA-MTA 63/50	4.0	353	91	1.1	7.9	0.25 kW					
MRS-MRT 28/50	3.3	420	101	1.5	7.8		min ⁻¹	i =	Nm	SF	kg
MRA-MTA 63/50	3.2	441	97	0.9	7.9	MRS-MRT 40	280	5	7.5	>3	8.3
MRS-MRT 28/50	2.5	560	127	1.2	7.8	MRS-MRT 40	200	7	10	>3	8.3
MRS-MRT 28/50	1.8	784	159	1.0	7.8	MRS-MRT 40	140	10	14	>3	8.3
MRS-MRT 28/50	1.3	1120	213	0.8	7.8	MRS-MRT 40	93	15	20	2.2	8.3
MRS-MRT 28/60	0.9	1568	260	1.0	11	MRS-MRT 40	70	20	26	1.5	8.3
MRS-MRT 40/70	0.6	2240	371	1.0	15	MRS-MRT 40	50	28	32	1.5	8.3
MRS-MRT 40/85	0.5	2800	447	1.3	19	MRS-MRT 40	35	40	42	1.0	8.3

1400 min⁻¹

Gear boxes Series RS and RT

Geared motors

Selection Table

0.25 kW						0.55 kW					
	min ⁻¹	i =	Nm	SF	kg		min ⁻¹	i =	Nm	SF	kg
MRA-MTA 71/50	32	44	59	2.5	12	MRA-MTA 80/85	8.0	176	396	1.3	26
MRS-MRT 50	29	49	52	1.5	9.6	MRA-MTA 80/85	5.5	252	520	1.0	26
MRS-MRT 50	25	56	57	1.3	9.6	MRA-MTA	4.6	309	614	1.8	49
MRA-MTA 71/50	22	63	80	1.7	12	MRA-MTA	4.0	353	689	1.4	49
MRS-MRT 50	20	70	63	1.0	9.6	MRS-MRT	3.3	420	756	1.1	49
MRS-MRT 60	18	80	72	1.5	12	MRA-MTA	3.2	441	794	1.2	49
MRA-MTA 71/50	95	95	109	1.2	12	MRA-MTA	2.8	504	851	0.9	49
MRS-MRT 60	14	100	88	1.0	12	MRS-MRT	2.5	570	962	1.3	49
MRA-MTA 71/60	11	126	144	1.6	15	MRS-MRT	1.8	784	1235	1.5	49
MRS-MRT 40/70	9.3	150	146	1.5	18						
MRA-MTA 71/60	8.0	176	171	1.4	15						
MRS-MRT 40/70	7.0	200	188	1.5	18						
MRA-MTA 71/70	5.5	252	232	1.3	18						
MRS-MRT 40/70	5.0	280	224	1.5	18						
MRA-MTA 71/70	4.6	309	263	1.0	18						
MRA-MTA 71/70	4.0	353	277	0.9	18						
MRS-MRT 40/70	3.3	420	315	1.2	18						
MRS-MRT 40/70	2.5	560	401	1.0	18						
MRS-MRT 40/85	1.8	784	535	1.1	22						
MRS-MRT 50/110	1.3	1120	707	1.8	46						
MRS-MRT 50/110	0.9	1568	882	1.5	46						
MRS-MRT 50/110	0.6	2240	1146	1.2	46						
MRS-MRT 50/110	0.5	2800	1289	0.9	46						
0.37 kW						0.75 kW					
	min ⁻¹	i =	Nm	SF	kg		min ⁻¹	i =	Nm	SF	kg
MRS-MRT 40	280	5	11	>3	8.7	MRS-MRT 50	280	5	23	>3	14
MRS-MRT 40	200	7	15	3.0	8.7	MRS-MRT 50	200	7	31	2.4	14
MRS-MRT 40	140	10	21	2.2	8.7	MRS-MRT 50	140	10	43	1.7	14
MRS-MRT 40	93	15	30	1.5	8.7	MRS-MRT 50	93	15	60	1.2	14
MRS-MRT 40	70	20	38	1.0	8.7	MRS-MRT 60	70	20	79	1.5	17
MRS-MRT 40	50	28	48	1.0	8.7	MRS-MRT 60	50	28	102	1.4	17
MRS-MRT 50	35	40	65	1.1	10	MRS-MRT 60	35	40	135	1.0	17
MRA-MTA 71/50	32	44	87	1.7	13	MRA-MTA 80/60	32	44	178	1.2	20
MRS-MRT 50	29	49	77	1.0	10	MRS-MRT 70	29	49	168	1.1	19
MRS-MRT 60	25	56	85	1.5	13	MRS-MRT 70	25	56	183	1.0	19
MRA-MTA 71/50	22	63	118	1.1	13	MRA-MTA 80/60	22	63	242	1.0	20
MRS-MRT 60	20	70	97	1.3	13	MRS-MRT 85	20	70	226	1.3	23
MRS-MRT 60	18	80	107	1.0	13	MRS-MRT 85	18	80	246	1.1	23
MRA-MTA 71/60	15	95	168	1.4	16	MRA-MTA 80/70	11	126	341	0.9	23
MRS-MRT 70	14	100	130	1.0	15	MRA-MTA 80/85	8.0	176	540	0.9	27
MRA-MTA 71/60	11	126	213	1.1	15	MRA-MTA	5.5	252	735	1.5	50
MRS-MRT 40/70	9.3	150	217	2.1	18	MRA-MTA	4.6	309	838	1.3	50
MRA-MTA 71/60	8.0	176	253	0.9	15	MRA-MTA	4.0	353	939	1.1	50
MRS-MRT 40/70	7.0	200	278	1.3	18	MRS-MRT	3.3	420	1031	1.2	50
MRA-MTA 71/70	5.5	252	343	0.9	18	MRA-MRT	3.2	441	1083	0.9	50
MRS-MRT 40/70	5.0	280	332	1.1	18	MRS-MRT	2.5	570	1289	1.0	50
MRS-MRT 40/85	3.3	420	488	1.2	23						
MRS-MRT 40/85	2.5	560	622	1.0	23						
MRS-MRT 50/110	1.3	1120	1046	1.2	47						
MRS-MRT 50/110	0.9	1568	1306	1.1	47						
0.55 kW						1.1 kW					
	min ⁻¹	i =	Nm	SF	kg		min ⁻¹	i =	Nm	SF	kg
MRS-MRT 40	280	5	16	2.8	10.7	MRS-MRT 60	280	5	34	>3	19
MRS-MRT 50	200	7	23	>3	12	MRS-MRT 60	200	7	45	2.5	19
MRS-MRT 50	140	10	32	2.4	12	MRS-MRT 60	140	10	63	2.1	19
MRS-MRT 50	93	15	44	1.7	12	MRS-MRT 60	93	15	91	1.4	19
MRS-MRT 50	70	20	57	1.1	12	MRS-MRT 60	70	20	116	1.1	19
MRS-MRT 50	50	28	75	1.1	12	MRS-MRT 70	50	28	158	1.4	21
MRS-MRT 60	35	40	99	1.4	15	MRS-MRT 70	35	40	213	1.1	21
MRA-MTA 80/60	32	44	130	1.7	19	MRA-MTA 80/70	32	44	264	1.1	25
MRS-MRT 60	29	49	114	1.1	15	MRS-MRT 85	29	49	246	1.3	26
MRS-MRT 60	25	56	126	1.0	15	MRS-MRT 85	25	56	286	1.1	26
MRA-MTA 80/60	22	63	177	1.2	19	MRA-MTA 80/85	22	63	364	1.4	30
MRS-MRT 70	20	70	155	1.1	18	MRS-MRT 110	20	70	352	1.8	48
MRS-MRT 70	18	80	168	1.0	18	MRS-MRT 110	18	80	396	1.3	48
MRA-MTA 80/60	15	95	249	1.0	19	MRA-MTA 80/85	15	95	513	1.0	30
MRS-MRT 85	14	100	210	1.0	22	MRS-MRT 110	14	100	458	1.0	48
MRA-MTA 80/70	11	126	321	1.1	22	MRA-MTA	11	126	671	1.6	52
						MRA-MTA	8.0	176	832	1.4	52
						MRA-MRT	5.5	252	1078	1.0	52
						MRA-MTA	4.6	309	1229	0.9	52
						MRA 100/130	3.5	400	1681	1.0	76
						MRS-MRT	3.3	420	1576	1.3	69
						MRA 100/150	3.0	448	1916	1.3	106
						MRA 100/150	2.5	560	2059	1.0	106
						MRA 100/150	2.2	640	2209	0.9	106
						MRS-MRT 70/150	1.8	784	2706	0.9	102
1.5 kW						2.2 kW					
	min ⁻¹	i =	Nm	SF	kg		min ⁻¹	i =	Nm	SF	kg
MRS-MRT 60	280	5	46	2.7	20	MRS-MRT 60	280	5	46	2.7	20
MRS-MRT 60	200	7	62	1.8	20	MRS-MRT 60	200	7	62	1.8	20
MRS-MRT 60	140	10	86	1.5	20	MRS-MRT 60	140	10	86	1.5	20
MRS-MRT 60	93	15	124	1.0	20	MRS-MRT 60	93	15	124	1.0	20
MRS-MRT 70	70	20	166	1.2	23	MRS-MRT 70	70	20	166	1.2	23
MRS-MRT 70	50	28	215	1.0	23	MRS-MRT 70	50	28	215	1.0	23
MRS-MRT 85	35	40	295	1.4	27	MRS-MRT 85	35	40	295	1.4	27

Gear boxes Series RS and RT

1400 min⁻¹

Selection Table

Geared motors

1.5 kW						4.0 kW					
	min ⁻¹	i =	Nm	SF	kg		min ⁻¹	i =	Nm	SF	kg
MRA-MTA 80/85	32	44	360	1.4	31	MRS 150	25	56	1115	1.3	130
MRS-MRT 85	29	49	336	0.9	27	MRS 150	20	70	1299	0.9	130
MRS-MRT 110	29	49	356	1.8	50	MRA 100/130	20	70	1433	0.9	93
MRS-MRT 110	25	56	401	1.5	50	MRA 100/150	18	80	1724	0.9	123
MRA-MTA 80/85	22	63	496	1.1	31	MRA 100/150	14	98	1845	1.2	123
MRS-MRT 110	20	70	480	1.3	50	MRA 100/150	12	120	2456	0.9	123
MRS-MRT 110	18	80	540	1.0	50						
MRA-MTA 80/110	15	95	719	1.6	54	5.5 kW					
MRS 130	14	100	624	1.2	64		min ⁻¹	i =	Nm	SF	kg
MRA-MTA 80/110	11	126	915	1.2	54	MRS-MRT 110	200	7	231	2.3	79
MRA-MTA 80/110	8.0	176	1135	1.0	54	MRS-MRT 110	140	10	326	1.6	79
MRA 100/130	7.0	200	1269	1.0	78	MRS-MRT 110	93	15	473	1.2	79
MRA 100/130	6.3	224	1421	1.2	78	MRS-MRT 110	70	20	623	1.0	79
MRA 100/150	5.0	280	1490	1.1	108	MRS 130	50	28	809	1.4	93
MRA 100/150	3.5	400	2292	1.1	108	MRS 130	35	40	1141	1.0	93
MRA 100/150	3.0	448	2613	1.0	108	MRS 150	29	49	1342	1.1	123
						MRS 150	27	53	1531	1.0	107
						MRS 150	25	56	1534	0.9	123
2.2 kW						7.5 kW					
	min ⁻¹	i =	Nm	SF	kg		min ⁻¹	i =	Nm	SF	kg
MRS-MRT 70	280	5	92	1.9	28	MRS-MRT 110	200	7	315	1.7	88
MRS-MRT 70	200	7	92	1.8	28	MRS-MRT 110	140	10	445	1.2	88
MRS-MRT 70	140	10	129	1.4	28	MRS-MRT 110	93	15	645	0.9	88
MRS-MRT 70	93	15	187	1.0	28	MRS 130	93	15	652	1.5	102
MRS-MRT 85	70	20	246	1.3	33	MRS 130	70	20	860	1.1	102
MRS-MRT 85	50	28	319	1.0	33	MRS 130	50	28	1103	1.0	102
MRS-MRT 110	35	40	438	1.6	55	MRS 150	35	40	1576	1.1	132
MRS-MRT 110	29	49	522	1.2	55	MRA 100/130	26	53	1041	1.4	116
MRS-MRT 110	25	56	588	1.0	55	MRA 100/150	25	56	1036	1.1	146
MRS-MRT 110	20	70	704	0.9	55						
MRS 130	18	80	756	1.1	69	11 kW					
MRS 150	14	100	945	1.2	99		min ⁻¹	i =	Nm	SF	kg
MRA 100/130	14	98	985	1.5	83	MRS 150	200	7	467	2.3	148
MRA 100/130	12	125	1369	1.3	83	MRS 150	140	10	660	1.9	148
MRA 100/130	10	140	1324	1.0	83	MRS 150	93	15	968	1.5	148
MRA 100/130	8.9	160	1729	1.0	83	MRS 150	70	20	1261	1.1	148
MRA 100/150	7.0	200	1861	1.1	113	MRS 150	50	28	1660	0.9	148
MRA 100/150	6.3	230	2175	1.2	113						
3.0 kW						15 kW					
	min ⁻¹	i =	Nm	SF	kg		min ⁻¹	i =	Nm	SF	kg
MRS-MRT 70	280	5	91	1.9	30	MRS 150	200	7	637	1.7	158
MRS-MRT 70	200	7	126	1.3	30	MRS 150	140	10	900	1.4	158
MRS-MRT 70	140	10	176	1.0	30	MRS 150	93	15	1320	1.1	158
MRS-MRT 85	93	15	255	1.1	35						
MRS-MRT 85	70	20	336	1.0	35						
MRS-MRT 110	50	28	435	1.5	57						
MRS-MRT 110	35	40	598	1.2	57						
MRS-MRT 110	29	49	712	0.9	57						
MRS 130	29	49	722	1.3	71						
MRS 130	25	56	814	1.2	71						
MRS 150	20	70	974	1.3	101						
MRA 100/130	20	70	1074	1.3	85						
MRS 150	18	80	1064	1.1	101						
MRA 100/130	18	80	1277	1.0	85						
MRS 150	14	100	1289	0.9	101						
MRA 100/130	14	98	1344	1.1	85						
MRA 100/130	12	120	1793	1.0	85						
MRA 100/150	10	140	1891	1.1	101						
MRA 100/150	8.9	160	2357	1.1	101						
4.0 kW											
	min ⁻¹	i =	Nm	SF	kg						
MRS-MRT 85	280	5	122	2.3	43						
MRS-MRT 85	200	7	168	1.5	43						
MRS-MRT 85	140	10	235	1.1	43						
MRS-MRT 110	93	15	344	1.6	65						
MRS-MRT 110	70	20	453	1.4	65						
MRS-MRT 110	50	28	581	1.1	65						
MRS 130	35	40	829	1.4	79						
MRS 130	29	49	963	1.0	79						
MRS 130	25	56	1085	0.9	79						

Gear boxes Series RS and RT

Electric Motors

Dimensions

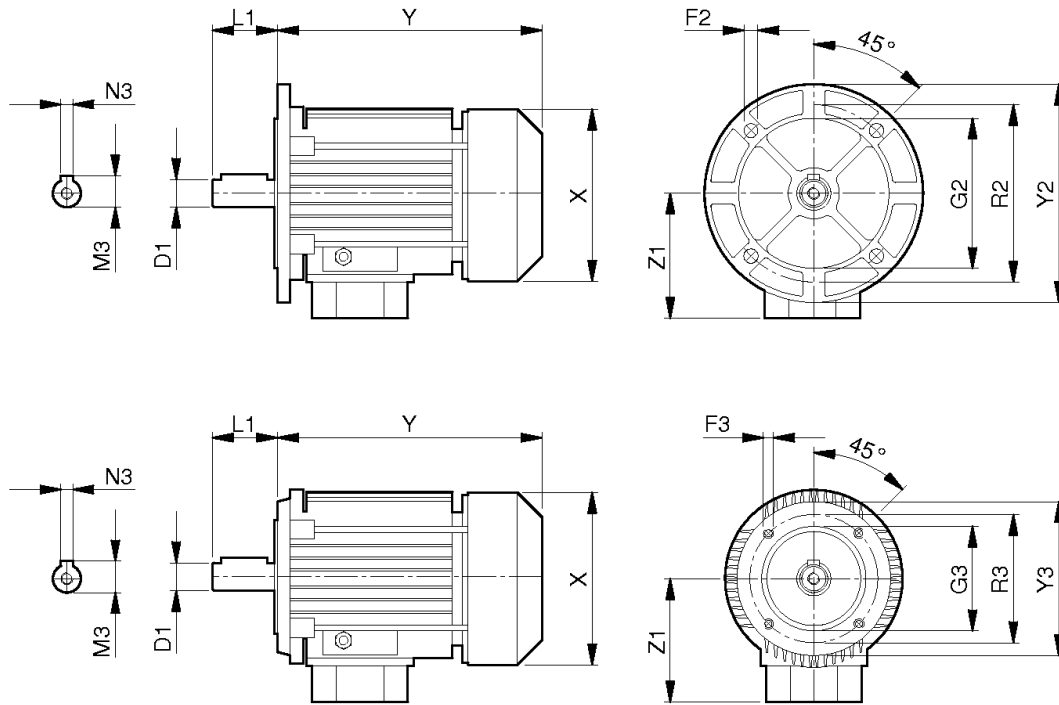

MOTOR IEC	56	63	71	80	90 S / L	100 / 112	132 S / M	160 M / L
$D_{1(j6)} \times L_1$	9 x 20	11 x 23	14 x 30	19 x 40	24 x 50	28 x 60	38 x 80	42 x 110
F ₂	7	9	9	11	11	14	14	18
F ₃	M.5	M.5	M.6	M.6	M.8	M.8	M.10	12
G _{2(j6)}	80	95	110	130	130	180	230	250
G _{3(j6)}	50	60	70	80	95	110	130	180
M ₃	10.4	12.8	16.3	21.8	27.3	31.3	41.3	45.3
N ₃	3	4	5	6	8	8	8	8
R ₂	100	115	130	165	165	215	265	300
R ₃	65	75	85	100	115	130	165	215
X	110	123	140	159	176	195 / 219	258	315
Y	168	185	215	238	255 / 280	309 / 328	368 / 405	478 / 522
Y ₂	120	140	160	200	200	250	300	350
Y ₃	80	90	105	120	140	160	200	250
Z ₁	108	110	121	138	149	160 / 172	192	220
Peso kg	2,5	4,5	6,0	10,0	13,5	21 / 29	43 / 52	68 / 78

Not binding dimensions

Gear boxes Series RS and RT

Dimensions

Single worm gear boxes RS

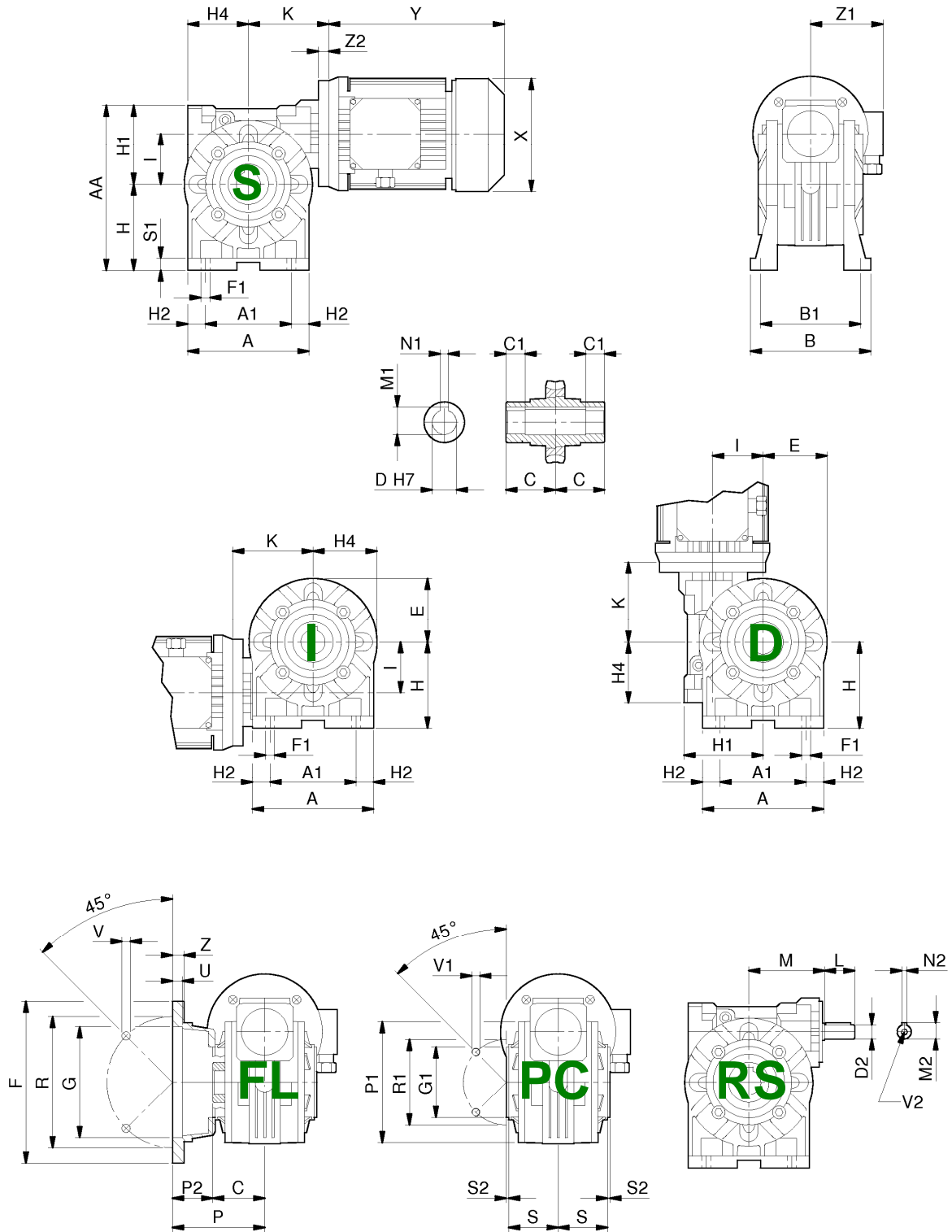

Gear boxes Series RS and RT

Single worm gear boxes RS

Dimensions

RS	28	40	50	60	70	85	110	130	150
A ₁	52	70	85	95	120	140	200	235	260
AA	99	138	163	192	221	252	342	400	454
B	78	102	119	136	140	168	200	230	250
B ₁	66	84	99	111	116	140	162	190	210
C	30	41	49	60	60	61	77,5	90	105
C ₁	26,5	26	30,5	39	37,5	38,5	52,5	85	100
D _(H7)	14	19	24	25	28	32	42	48	55
D* _(H7)	---	18	25	---	30	35	---	---	---
D _{2 (h6)}	9	11	14	19	19	24	28	38	42
E	34	50	61	70	80	98	125	143	168
F	70	140	160	180	200	200	250	300	350
F ₁	5,5	7	9	11	11	13	14	15	19
G _(H8)	40	95	110	115	130	130	180	230	250
G _{1 (f8)}	42	60	70	70	80	110	130	180	180
H	52	71	85	100	115	135	172	200	230
H ₁	47	67	78	92	106	117	170	200	224
H ₂	9	15	17,5	21,5	19	26,5	25	25,5	38
H ₄	40	50	60	72	86	103	142	159	183
I	28	40	50	60	70	85	110	130	150
K	57,5	70,5	83-88*	93-94*	117-118*	134-137*	151-153*	165-166*	191-211*
L	20	23	30	40	40	40	60	80	100
M	50	65	75	87	110	123,5	146	166	195
M ₁	16,3	21,8	27,3	28,3	31,3	35,3	45,3	51,8	59,3
M ₂	10,2	12,5	16	22,5	22,5	27	31	41	45
N ₁	5	6	8	8	8	10	12	14	16
N ₂	3	4	5	6	6	8	8	10	12
P	49	82	91,5	116	111	100	150	150	160
P ₁	67	94	100	102	118	150	200	234	250
P ₂	19	41	42,5	56	51	39	72,5	60	55
R	56	115	130	150	165	165	215	265	300
R ₁	56	83	85	85	100	130	165	215	215
S	32	38	49	57,5	57	56,5	74,5	87	102
S ₁	6	9	12	12	14	15	17	19	20
S ₂	-3	2	2,5	2,5	3	3	2,5	5	5
U	4	6	10	10	12	6	5	5	6
V	6,5 (4)	9 (4)	9 (4)	11 (4)	13 (4)	13 (4)	15 (8)	15 (8)	19 (8)
V ₁	M6x6 (4)	M6x9 (4)	M8x12 (4)	M8x15 (8)	M8x18 (8)	M10x20 (8)	M12x21 (4)	M12x24 (4)	M14x30 (8)
V ₂	M4x10	M4x10	M6x15	M8x20	M8x20	M8x20	M8x20	M10x22	M12x25
Z	6	10	10	11	14	14	16	18	20

D* - Bores on request

V₁ - 90° for RS28

(*) - IEC71-B14 (FRS50) – IEC71-B14 (FRS60) – IEC 80-B14 (FRS70) – IEC 90-B14 (FRS85)

(*) - IEC100/112-B14 (FRS110) – IEC 100/112-B5 (FRS130) – IEC 160-B5 (FRS150)

Motor Dimensions: page 25

Not binding dimensions

Gear boxes Series RS and RT

Dimensions

Helical worm gear boxes RA

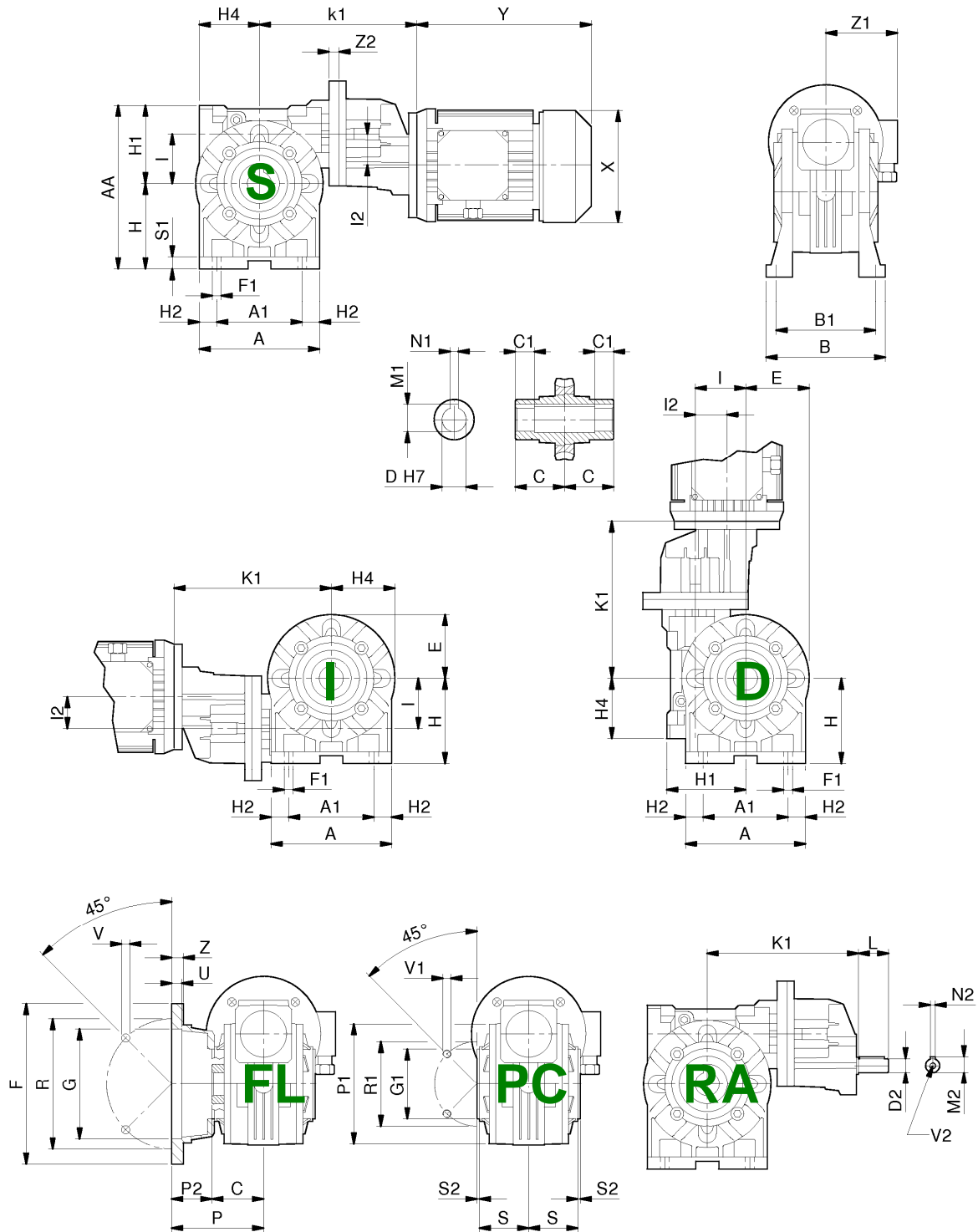

Gear boxes Series RS and RT

Helical worm gear boxes RA

Dimensions

RA	63/40	63/50	63/60	71/50	71/60	71/70	71/85	80/60	80/70	80/85	80/110	100/110	100/130	100/150
A ₁	70	85	95	85	95	120	140	95	120	140	200	250	235	260
AA	138	163	192	163	192	221	252	192	221	252	342	200	400	454
B	102	119	136	119	136	140	168	136	140	168	200	333	230	250
B ₁	84	99	111	99	111	116	140	111	116	140	162	200	190	210
C	41	49	60	49	60	60	61	60	60	61	77,5	162	90	105
C ₁	26	30,5	39	30,5	39	37,5	38,5	39	37,5	38,5	52,5	52,5	85	
D	19	24	25	24	25	28	32	25	28	32	42	77,5	48	55
D*	18	25	---	25	---	30	35	---	30	35	---	42	---	---
D ₂	11	11	11	14	14	14	14	19	19	19	19	---	19	19
E	50	61	70	61	70	80	98	70	80	98	125	24	143	168
F	140	160	180	160	180	200	200	180	200	200	250	125	300	350
F ₁	7	9	11	9	11	11	13	11	11	13	14	250	15	19
G	95	110	115	110	115	130	130	115	130	130	180	14	230	250
G ₁	60	70	70	70	70	80	110	70	80	110	130	180	180	180
H	71	85	100	85	100	115	135	100	115	135	172	130	200	230
H ₁	67	78	92	78	92	106	117	92	106	117	170	172	200	224
H ₂	15	17,5	21,5	17,5	21,5	19	26,5	21,5	19	26,5	25	161	25,5	38
H ₄	50	60	72	60	72	86	103	72	86	103	142	25	159	189
I	40	50	60	50	60	70	85	60	70	85	110	139	130	150
I ₁	32	32	32	40	40	40	40	50	50	50	50	110	75	75
K	153,	171	177	173	183	209	224	207	232,	250,	264,	63	290	316
				178*	188*	214*	229*					328	300*	326*
L	23	23	23	30	30	30	30	40	40	40	40	50	40	40
M ₁	21,8	27,3	28,3	27,3	28,3	31,3	35,3	28,3	31,3	35,3	45,3	45,3	51,8	59,3
M ₂	12,5	12,5	12,5	16	16	16	16	22,5	22,5	22,5	22,5	27	22,5	22,5
N ₁	6	8	8	8	8	8	10	8	8	10	12	12	14	16
N ₂	4	4	4	5	5	5	5	6	6	6	6	8	6	6
P	82	91,5	116	91,5	116	111	100	116	111	100	150	150	150	160
P ₁	94	100	102	100	102	118	150	102	118	150	200	200	234	250
P ₂	41	42,5	56	42,5	56	51	39	56	51	39	72,5	72,5	60	55
R	115	130	150	130	150	165	165	150	165	165	215	215	265	300
R ₁	83	85	85	85	85	100	130	85	100	130	165	165	215	215
S	38	49	57,5	49	57,5	57	56,5	57,5	57	56,5	74,5	74,5	87	102
S ₁	9	12	12	12	12	14	15	12	14	15	17	17	19	20
S ₂	2	2,5	2,5	2,5	2,5	3	3	2,5	3	3	2,5	2,5	5	5
U	6	10	10	10	10	12	6	10	12	6	5	5	5	6
V	9 (4)	9 (4)	11 (4)	9 (4)	11 (4)	13 (4)	13 (4)	11 (4)	13 (4)	13 (4)	15 (8)	15 (8)	15 (8)	19 (8)
V ₁	M6x9 (4)	M8x12 (4)	M8x15 (8)	M8x12 (4)	M8x15 (8)	M8x18 (8)	M10x2 (8)	M8x15 (8)	M8x18 (8)	M10x2 (8)	M12x2 (8)	M12x2 (8)	M12x2 (8)	M14x3 (8)
V ₂	M4x10	M4x10	M4x10	M6x15	M6x15	M6x15	M6x15	M8x20	M8x20	M8x20	M8x20	M8x20	M8x20	M8x20
Y ₁	105	105	105	120	120	120	120	140	140	140	140	140	200	200
Z	10	10	11	10	11	14	14	11	14	14	16	16	18	20

D* - Bores on request

V₁ - 90° for RS28

(*) - IEC71-B14 (FRA 71/....) - IEC100-B5 (FRA130) - IEC100-B5 (FRA150)

Motor Dimensions: page 25

Not binding dimensions

Gear boxes Series RS and RT

Dimensions

Double worm gear boxes RS/RS

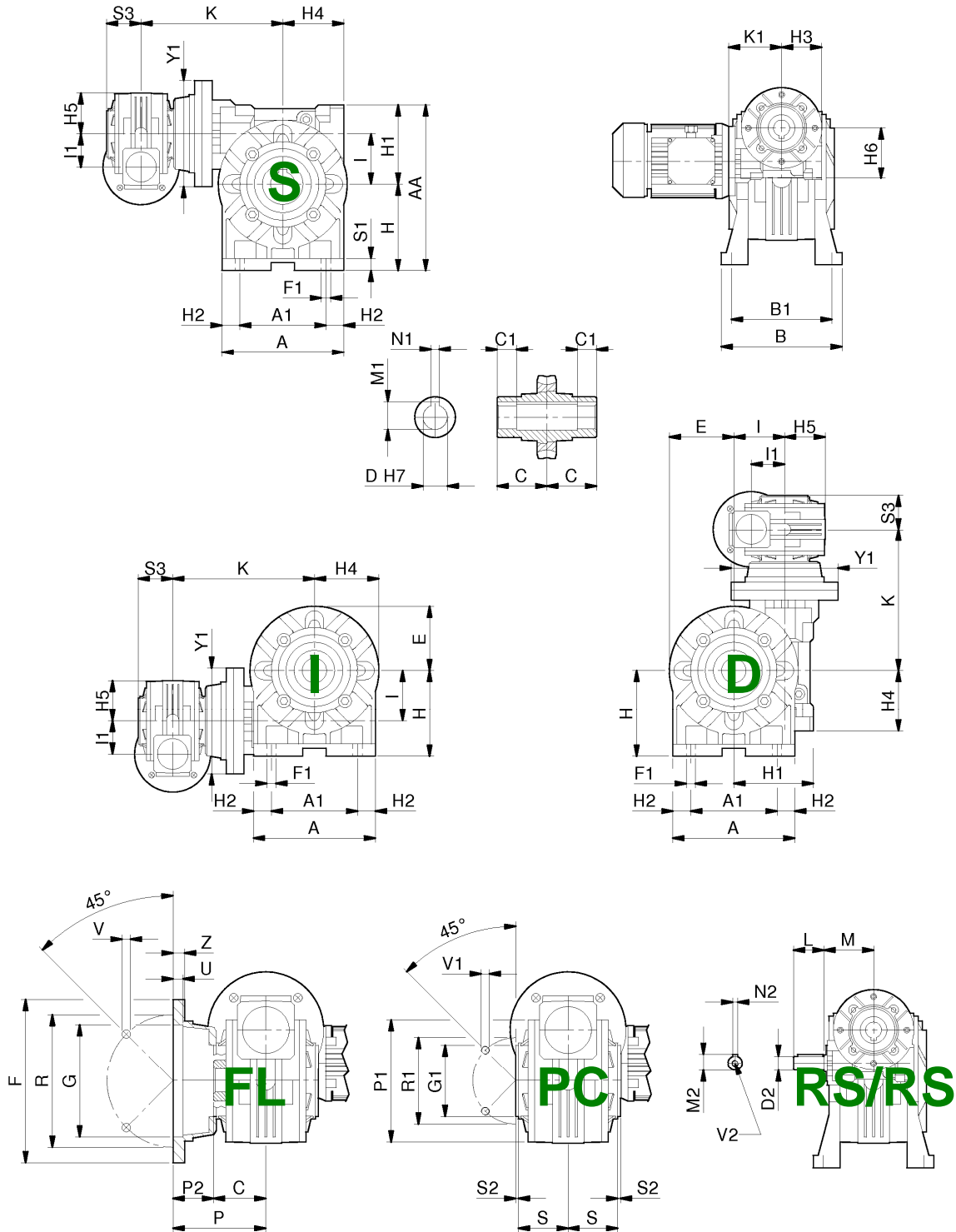

Gear boxes Series RS and RT

Double worm gear boxes RS/RS

Dimensions

RS/RS	28/28	28/40	28/50	28/60	40/70	40/85	50/110	60/130	70/150
A ₁	52	70	85	95	120	140	200	235	260
AA	99	138	163	192	221	252	342	400	454
B	78	102	119	136	140	168	200	230	250
B ₁	66	84	99	111	116	140	162	190	210
C	30	41	49	60	60	61	77,5	90	105
C ₁	26,5	26	30,5	39	37,5	38,5	52,5	85	100
D ^(H7)	14	19	24	25	28	32	42	48	55
D* ^(H7)	---	18	25	---	30	35	---	---	---
D ₂ ^(h6)	9	9	9	9	11	11	14	38	42
E	34	50	61	70	80	98	125	143	168
F	70	140	160	180	200	200	250	300	350
F ₁	5,5	7	9	11	11	13	14	15	19
G ^(H8)	40	95	110	115	130	130	180	230	250
G ₁ ^(f8)	42	60	70	70	80	110	130	180	180
H	52	71	85	100	115	135	172	200	230
H ₁	47	67	78	92	106	117	170	200	224
H ₂	9	15	17,5	21,5	19	26,5	25	25,5	38
H ₃	40	40	40	40	50	50	60	72	86
H ₄	40	50	60	72	86	103	142	159	189
H ₅	34	34	34	34	50	50	61	70	80
H ₆	47	47	47	47	67	67	78	92	106
I	28	40	50	60	70	85	110	130	150
I ₂	28	28	28	28	40	40	50	60	70
K	99,5	123	138,5	146	182	199	246	246	300
K ₁	57,5	57,5	57,5	57,5	70,5	70,5	83 - 88*	93 - 94*	117 - 118*
L	20	20	20	20	23	23	30	40	40
M	50	50	50	50	65	65	75	87	110
M ₁	16,3	21,8	27,3	28,3	31,3	35,3	45,3	51,8	59,3
M ₂	10,2	10,2	10,2	10,2	12,5	12,5	16	22,5	22,5
N ₁	5	6	8	8	8	10	12	14	16
N ₂	3	3	3	3	4	4	5	6	6
P	49	82	91,5	116	111	100	150	150	160
P ₁	67	94	100	102	118	150	200	234	250
P ₂	19	41	42,5	56	51	39	72,5	60	55
R	56	115	130	150	165	165	215	265	300
R ₁	56	83	85	85	100	130	165	215	215
S	32	38	49	57,5	57	56,5	74,5	87	102
S ₁	6	9	12	12	14	15	17	19	20
S ₂	-3	2	2,5	2,5	3	3	2,5	5	5
S ₃	30	30	30	30	41	41	49	60	60
U	4	6	10	10	12	6	5	5	6
V	6,5 (4)	9 (4)	9 (4)	11 (4)	13 (4)	13 (4)	15 (8)	15 (8)	19 (8)
V ₁	M6x6 (4)	M6x9 (4)	M8x12 (4)	M8x15 (8)	M8x18 (8)	M10x20 (8)	M12x21 (4)	M12x24 (4)	M14x30 (4)
V ₂	M4x10	M4x10	M4x10	M4x10	M4x10	M4x10	M6x15	M8x20	M8x20
Y ₁	80	80	80	90	115	115	110	180	200
Z	6	10	10	11	14	14	16	18	20

D* - Bores on request

V₁ - 90° for RS28

(*) - IEC71-B14 (FRS50) - IEC71-B14 (FRS60) - IEC 80-B14 (FRS70)

Motor Dimensions: page 25

Not binding dimensions

Gear boxes Series RS and RT

Dimensions

Alternative Mountings RS

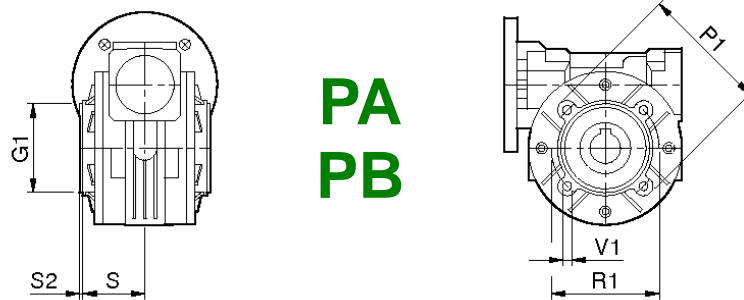
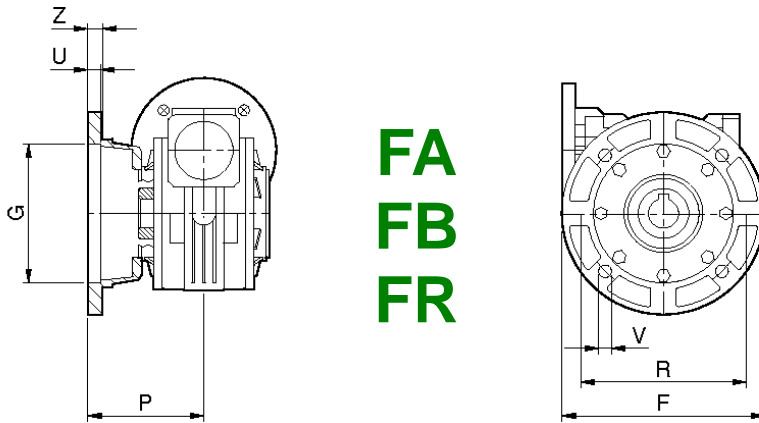
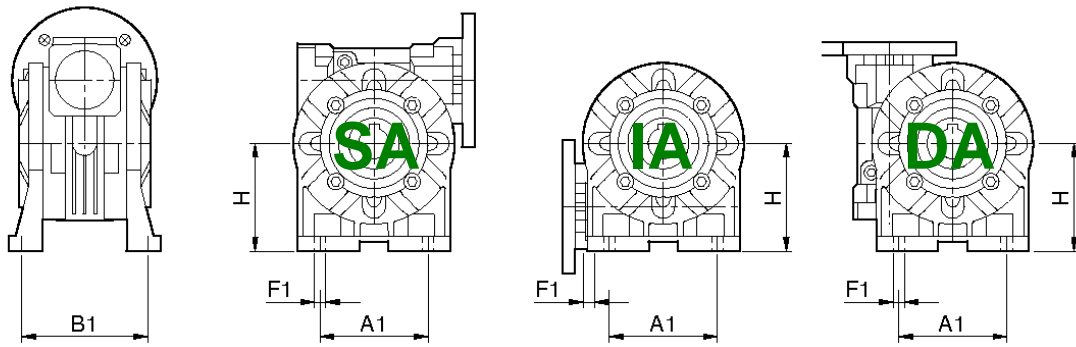

Gear boxes Series RS and RT

Alternative Mountings RS

Dimensions

RS	28	40	50	60	70	85	110	130	150
SA-IA-DA									
A ₁	---	52	63	---	---	140	---	---	---
B ₁	---	81	98.5	---	---	146	---	---	---
F ₁	---	8.5	9	---	---	11	---	---	---
H	---	72	82	---	---	142	---	---	---
FA									
F	80	114	125	165	165	---	---	---	---
G _(H8)	50	60	70	110	115	---	---	---	---
P	50.5	69	93	90	116	---	---	---	---
R	68	87	90	130	150	---	---	---	---
U	3.5	5	5	10	4.5	---	---	---	---
V	6.5 (4)	9 (4)	11 (4)	10.5 (4)	11 (4)	---	---	---	---
Z	7	8	10	15	10	---	---	---	---
FB									
F	---	120	---	180	---	210	270	---	---
G _(H8)	---	80	---	115	---	152	170	---	---
P	---	62	---	86	---	119.5	131.5	---	---
R	---	100	---	150	---	176	230	---	---
U	---	4	---	3.5	---	5	5	---	---
V	---	9 (4)	---	11 (4)	---	11 (4)	13 (4)	---	---
Z	---	9	---	12	---	14	18	---	---
FR									
F	---	---	---	---	160	---	---	---	---
G _(H8)	---	---	---	---	110	---	---	---	---
P	---	---	---	---	84.5	---	---	---	---
R	---	---	---	---	130	---	---	---	---
U	---	---	---	---	4.5	---	---	---	---
V	---	---	---	---	11 (4)	---	---	---	---
Z	---	---	---	---	14	---	---	---	---
PA									
G _{1(H8)}	---	50	68	75	90	---	---	---	---
P ₁	---	95	110	104	125	---	---	---	---
R ₁	---	65	94	90	110	---	---	---	---
S	---	38	49	47.5	55	---	---	---	---
S ₂	---	2	2.5	5.5	3	---	---	---	---
V ₁	---	M6x8 (4)	M6x12.5(4)	M8x14 (4)	M8x14 (4)	---	---	---	---
PB									
G _{1(H8)}	---	---	60	---	70	---	---	---	---
P ₁	---	---	110	---	116	---	---	---	---
R ₁	---	---	75	---	85	---	---	---	---
S	---	---	49	---	67	---	---	---	---
S ₂	---	---	2.5	---	4	---	---	---	---
V ₁	---	---	M6x12.5(4)	---	M8x14 (4)	---	---	---	---

Not binding dimensions

Gear boxes Series RS and RT

Dimensions

Accessories RS

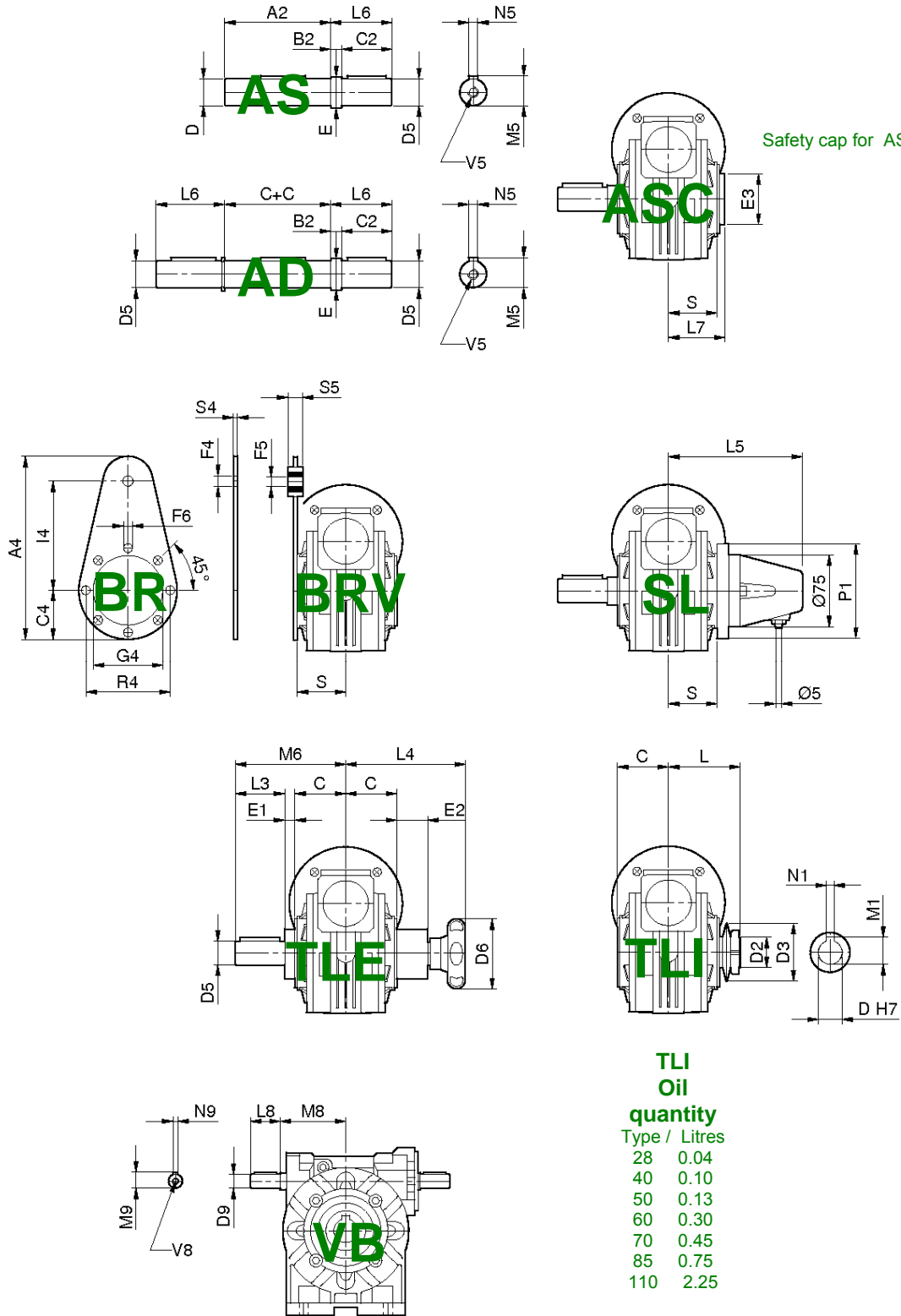

Gear boxes Series RS and RT

Accessories RS

Dimensions

RS		28	40	50	60	70	85	110	130	150
AS & AD	A ₂	58	80	95	117	117	119	153	177	207
	B ₂	1	10	10	10	10	10	10	20	20
	C	30	41	49	60	60	61	77.5	90	105
	C ₂	30	40	45	50	60	70	100	110	110
	D _{5 (g6)}	14	19 (18)	24 (25)	25	28	32 (35)	42	48	55
	E	14	22	28	30	34	38	50	58	63
	L ₆	31	50	55	60	70	80	106	130	130
	M ₅	16	21.5	27	28	31	35	45	51.5	59
	N ₅	5	6	8	8	8	10	12	14	16
	V ₅	M5x10	M8x20	M8x20	M8x20	M8x20	M10x25	M10x25	---	---
<hr/>										
ASC	E ₃	42	55	62	62	72	90	120	---	---
	L ₇	36	48.5	55.5	68.5	67	77	85	---	---
	S	27.5	38.5	46.5	57	57	67	74	---	---
<hr/>										
BR BRV	A ₄	138	168	185	235	295	313	388	---	---
	C ₄	38	43	60	55	65	75	100	---	---
	F ₄	10.5	10.5	10.5	10.5	10.5	20.5	20.5	---	---
	F ₅	10	10	10	10	10	20	20	---	---
	F ₆	7	7	9	9	9	12	13	---	---
	G ₄	55	60	70	80	95	110	130	---	---
	I ₄	80	100	100	150	150	200	250	---	---
	R ₄	65	75	85	95	115	130	165	---	---
	S ₄	4	4	4	6	6	6	6	---	---
	S ₅	15	15	15	20	20	25	25	---	---
<hr/>										
SL	L ₅	100	110	120	130	130	140	155	---	---
	P ₁	77	88	100	110	132	160	200	---	---
	S	27.5	38.5	46.5	57	57	67	74	---	---
<hr/>										
TLE	D ₆	52	70	70	70	80	100	100	---	---
	E ₁	10	12	12	15	14	19	24	---	---
	E ₂	28	37	31	40	46	57	71	---	---
	L ₃	30	40	50	50	60	70	80	---	---
	L ₄	94	116	118	128	146	168	201	---	---
	M ₆	70	93	111	125	134	150	181	---	---
<hr/>										
TLI	D _(H7)	14	19	24	25	28	32	42	---	---
	D ₂	40	56	71	71	80	90	125	---	---
	D ₃	14.2 x 20	19.5 x 20.5	24.5 x 28	25.5 x 26	28.5 x 22	32.5 x 27	42.5 x 38.5	---	---
	L	45	61.5	77	86.5	89	94	109	---	---
	M ₁	15.4*	21.8	27.3	27.3*	31.3	35.3	45.3	---	---
	N _{1 (H9)}	5	6	8	8	8	10	12	---	---
<hr/>										
VB	D ₉	9	11	14	19	19	24	28	---	---
	L ₈	20	23	30	40	40	50	60	---	---
	M ₈	43	55	65	77	84	106.5	145	---	---
	M ₉	10.2	12.5	16	22.5	22.5	27	31	---	---
	N ₉	3	4	5	6	6	8	8	---	---
	V ₈	M4x10	M4x10	M6x15	M8x20	M8x20	M8x20	M8x20	---	---

* = Undersized key

- D₅ (..) = Diametre on request

Gear boxes Series RS and RT

Dimensions

Single worm gear boxes RT

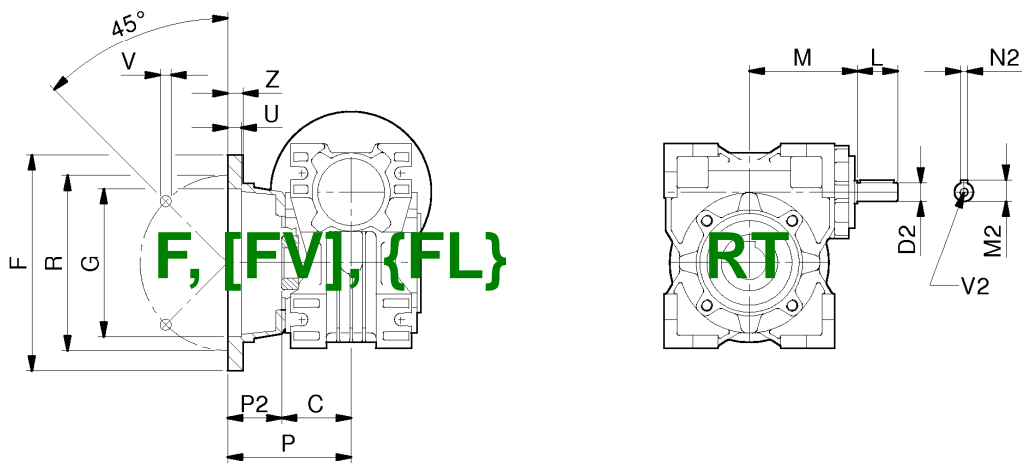
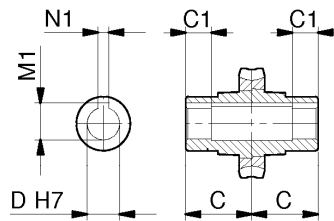
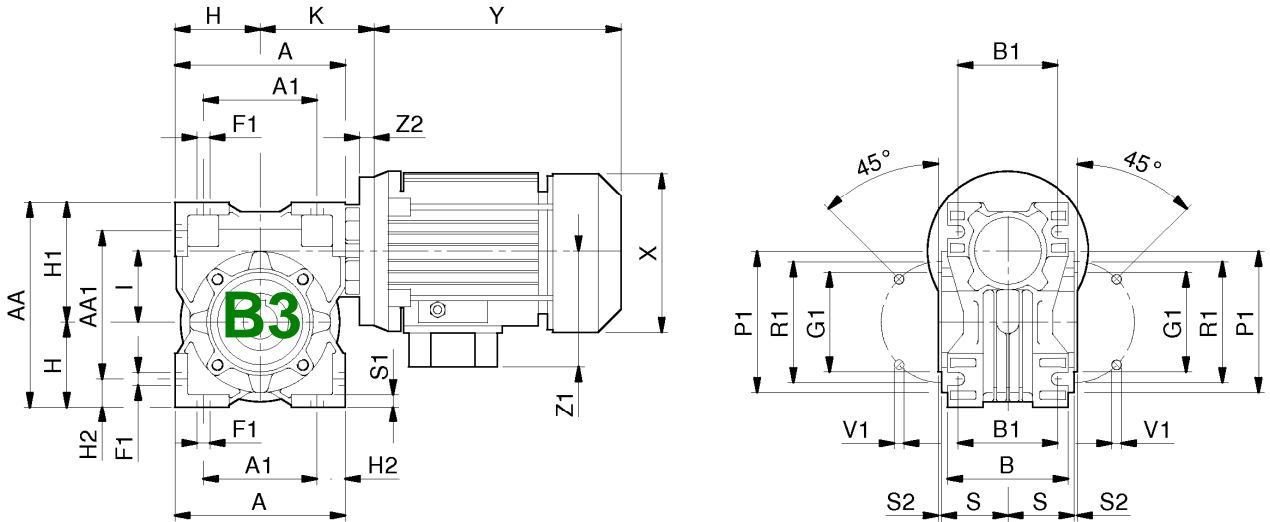

Gear boxes Series RS and RT

Single worm gear boxes RT

Dimensions

RT	28	40	50	60	70	85	110
A	80	100	120	144	172	206	255
A ₁	54	70	80	100	120	140	170
AA	97	121,5	144	174	205	238	295
AA ₁	71	91,5	104	130	153	172	210
B	53	71	85	100	112	130	144
B ₁	44	60	70	85	90	100	115
C	14	41	49	60	60	61	77,5
C ₁	26,5	26	30,5	39	37,5	38,5	52,5
D _(H7)	14	19	24	25	28	32	42
D* _(H7)	---	18	25	---	30	35	---
D _{2 (h6)}	9	11	14	19	19	24	28
F	80	110 {110}	125 [160] 125}	180 {180}	200	210	270
F ₁	7	7	9	9	11	13	15
G _(H8)	50	60 {60}	70 [110] {70}	115 {115}	130	152	170
G _{1 (h8)}	55	60	70	80	95	110	130
H	40	50	60	72	86	103	127,5
H ₁	57	71,5	84	102	119	135	167,5
H ₂	13	15	20	22	26	33	42,5
I	28	40	50	60	70	85	110
K	57,5	70,5	83-88*	93-94*	117-118*	134-137*	151-153*
L	20	23	30	40	40	50	60
M	50	65	75	87	110	123,5	146
M ₁	16,3	21,8	27,3	28,3	31,3	35,3	45,3
M ₂	10,2	12,5	16	22,5	22,5	27	31
N ₁	5	6	8	8	8	10	12
N ₂	3	4	5	6	6	8	8
P	53	69 {99}	93 [90,5] {123}	86 {116}	111	111	131
P ₁	75	86	100	110	130	160	200
P ₂	23	28 {58}	44 [41,5] {74}	25 {56}	51	50	53,5
R	68	87 {87}	90 [130] {90}	150,5 {150,5}	165	175	230
R ₁	65	75	85	95	115	130	165
S	27,5	38,5	46,5	57	57	67	74
S ₁	6	7	8	10	11	14	13
S ₂	2,5	2,5	3	3	3	3	3,5
U	10	4 {4}	5 [11] {5}	6,5 {6,5}	12	6	5
V	7	9 {9}	10,5 [9] {9}	11 {11}	13	13	14
V ₁	M6x10 (4)	M6x8,5 (4)	M8x10 (4)	M8x16 (8)	M8x16 (8)	M10x18 (8)	M10x21 (8)
V ₂	M4x10	M4x10	M6x15	M8x20	M8x20	M8x20	M8x20
Z	7	6 {8}	10 [13] {10}	10 {10}	14	16	18
Z ₂	13	13	13 - 18,5	14 - 15	15,5 - 17,5	15,5 - 18,5	18-20

D* - Bores on request

V₁ - 90° for RT28

(*) - IEC71-B14 (**FRS50**) - IEC71-B14 (**FRS60**) - IEC 80-B14 (**FRS70**) - IEC 90-B14 (**FRS85**) - IEC100/112-B14 (**FRS110**)

Motor Dimensions: page 25

Not binding dimensions

Gear boxes Series RS and RT

Dimensions

Helical worm gear boxes TA

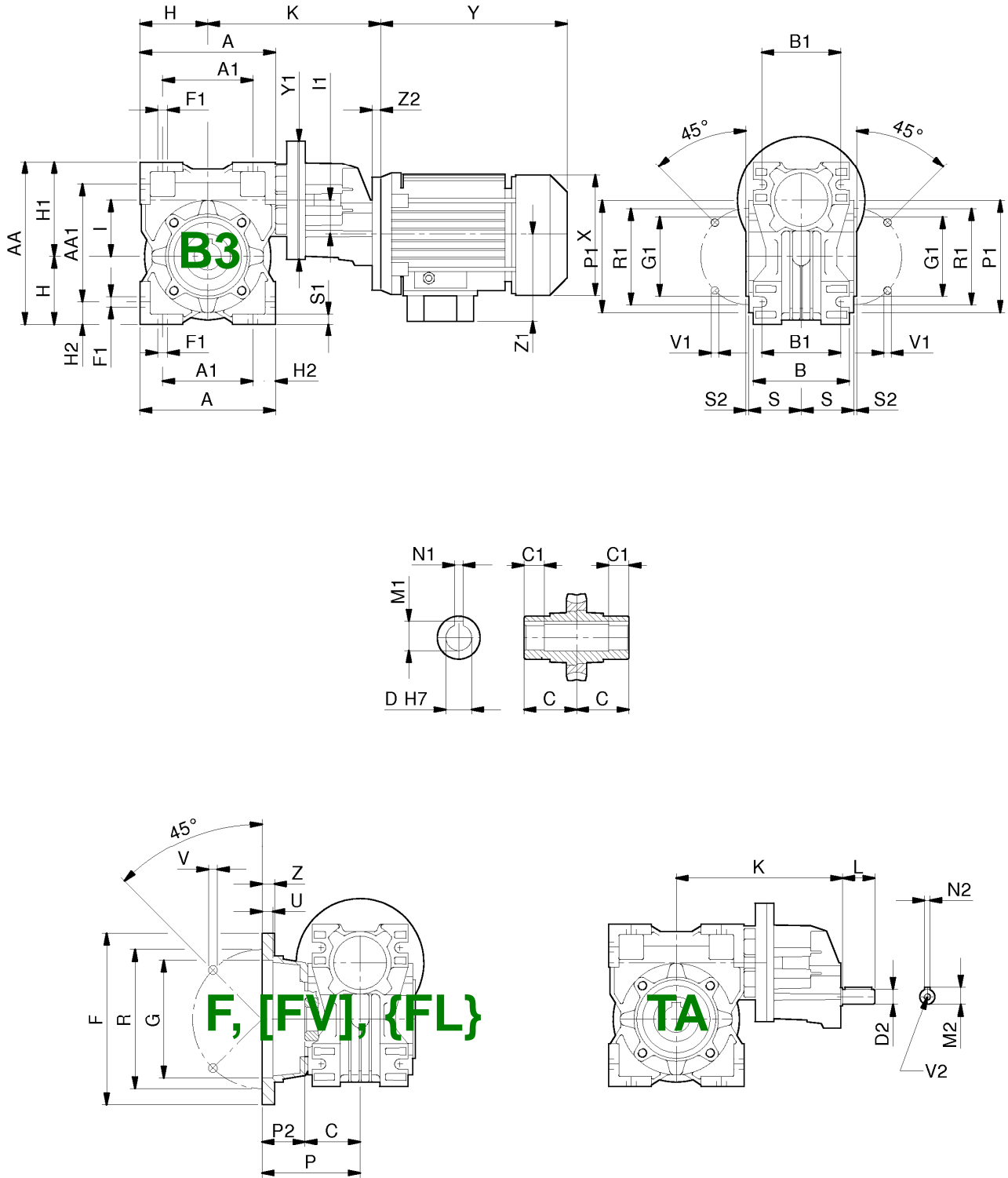

Gear boxes Series RS and RT

Helical worm gear boxes TA

Dimensions

TA	63/40	63/50	63/60	71/50	71/60	71/70	71/85	80/60	80/70	80/85	80/110	100/110
A	100	120	144	120	144	172	206	144	172	206	255	255
A ₁	70	80	100	80	100	120	140	100	120	140	170	170
AA	121,5	144	174	144	174	205	238	174	205	238	295	295
AA ₁	91,5	104	130	104	130	153	172	130	153	172	210	210
B	71	85	100	85	100	112	130	100	112	130	144	144
B ₁	60	70	85	70	85	90	100	85	90	100	115	115
C	41	49	60	49	60	60	61	60	60	61	77,5	77,5
C ₁	26	30,5	39	30,5	39	37,5	38,5	39	37,5	38,5	52,5	52,5
D ^(H7)	19	24	25	24	25	28	32	25	28	32	42	42
D*	18	25	---	25	---	30	35	---	30	35	---	---
D ₄ (h6)	11	11	11	14	14	14	14	19	19	19	19	24
F	110	125	180	125	180	200	210	180	200	210	270	270
F ₁	7	9	9	9	9	11	13	9	11	13	15	15
G ^(H8)	60 {60}	70 [110]	115	70 [110]	115	130	152	115	130	152	170	170
G ₁ (h8)	60	70	80	70	80	95	110	80	95	110	130	130
H	50	60	72	60	72	86	103	72	86	103	127,5	127,5
H ₁	71,5	84	102	84	102	119	135	102	119	135	167,5	167,5
H ₂	15	20	22	20	22	26	33	22	26	33	42,5	42,5
I	40	50	60	50	60	70	85	60	70	85	110	110
I ₁	32	32	32	40	40	40	40	50	50	50	50	50
K	153,5	171	177	173-	183	209-	224	207	232,5	250,5	264,5	328
L	23	23	23	30	30	30	30	40	40	40	40	50
M ₁	21,8	27,3	28,3	27,3	28,3	31,3	35,3	28,3	31,3	35,3	45,3	45,3
M ₂	12,5	12,5	12,5	16	16	16	16	22,5	22,5	22,5	22,5	27
N ₁	6	8	8	8	8	8	10	8	8	10	12	12
N ₄	4	4	4	5	5	5	5	6	6	6	6	8
P	69 {99}	93	86 {116}	93	86 {116}	111	111	86 {116}	111	111	131	131
P ₁	86	100	110	100	110	130	160	110	130	160	200	200
P ₂	28 {58}	44	25 {56}	44	25 {56}	51	50	25 {56}	51	50	53,5	53,5
R	87	90	150,5	90 [130]	150,5	165	175	150,5	165	175	230	230
R ₁	75	85	95	85	95	115	130	95	115	130	165	165
S	38,5	46,5	57	46,5	57	57	67	57	57	67	74	74
S ₁	7	8	10	8	10	11	14	10	11	14	13	13
S ₂	2,5	3	3	3	3	3	3	3	3	3	3,5	3,5
U	4 {4}	5 [11] {5}	6,5 {6,5}	5 [11] {5}	6,5 {6,5}	12	6	6,5 {6,5}	12	6	5	5
V	9 {9}	10,5 [9]	11	10,5 [9]	11	13	13	11	13	13	14	14
V ₁	M6x8 (4)	M8x10 (4)	M8x16 (8)	M8x10 (4)	M8x16 (8)	M8x16 (8)	M10x18	M8x16 (8)	M8x16 (8)	M10x18 (8)	M10x21 (8)	M10x21 (8)
V ₃	M4 x 10	M4 x 10	M4 x 10	M6 x 15	M6 x 15	M6 x 15	M6 x 15	M8 x 20	M8 x 20	M8 x 20	M8 x 20	M8 x 20
Y ₁	105	105	105	120	120	120	120	140	140	140	140	140
Z	6 {8}	10 [13] {10}	10 {10}	10 [13] {10}	10 {10}	14	16	10 {10}	14	16	18	18
Z ₂	13	13	13	13 -	13 -	13 -	13 -	14 -	14 -	14 -	14 -	14 - 15

D* - Bores on request

V₁ - 90° for RT28

(*) - IEC71-B14 (FTA 71/....)

Motor Dimensions: page 25

Not binding dimensions

Gear boxes Series RS and RT

Dimensions

Double worm gear boxes RT/RT

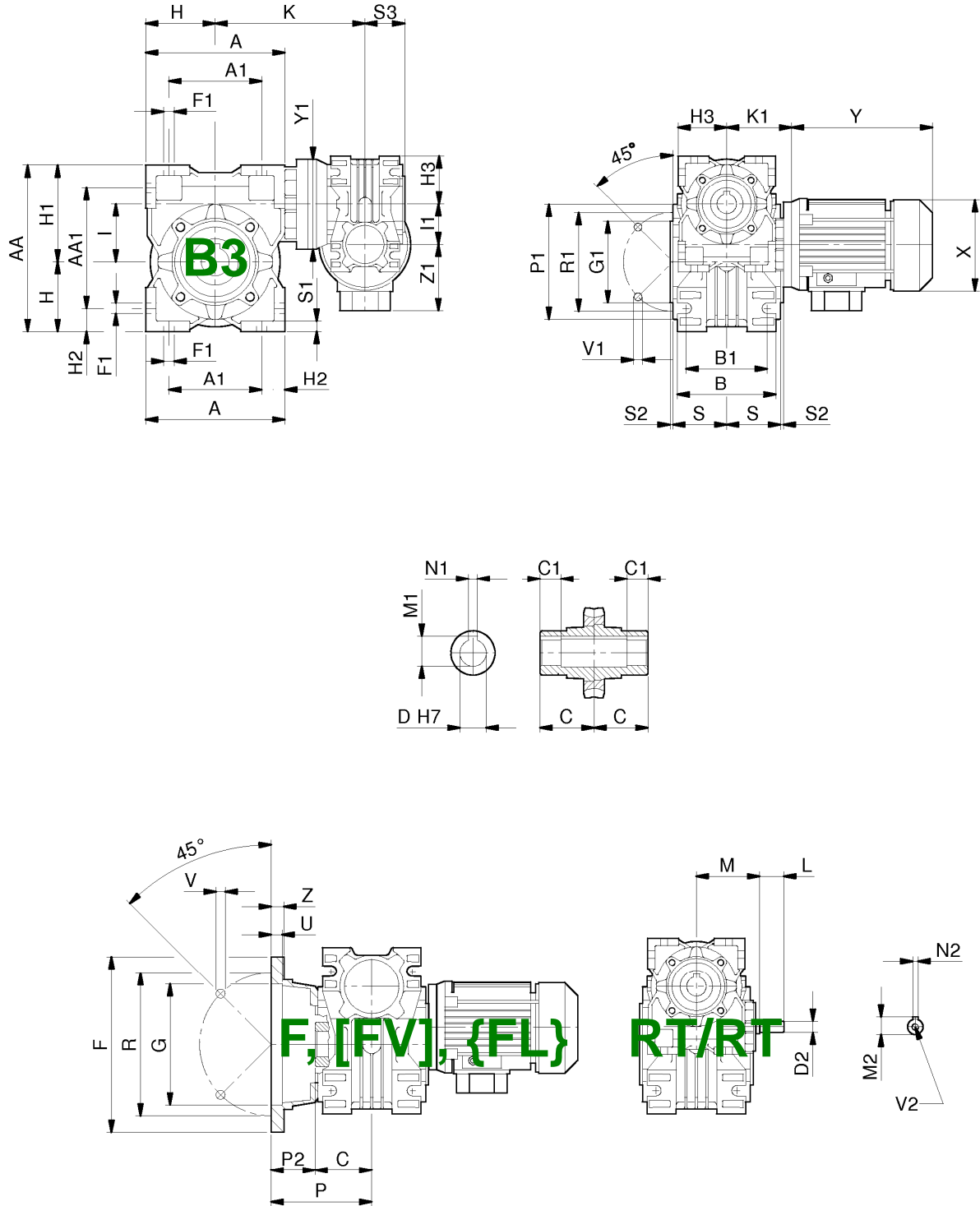

Gear boxes Series RS and RT

Double worm gear boxes RT/RT

Dimensions

RT/RT	28/28	28/40	28/50	28/60	40/70	40/85	50/110
A	80	100	120	144	172	206	255
A ₁	54	70	80	100	120	140	170
AA	97	121,5	144	174	205	238	295
AA ₁	71	91,5	104	130	153	172	210
B	53	71	85	100	112	130	144
B ₁	44	60	70	85	90	100	115
C	30	41	49	60	60	61	77,5
C ₁	26,5	26	30,5	39	37,5	38,5	52,5
D (H7)	14	19	24	25	28	32	42
D* (H7)	---	18	25	---	30	35	---
D ₂ (h6)	9	9	9	9	11	11	14
F	80	110 {110}	125 [160] {125}	180 {180}	200	210	270
F ₁	7	7	9	9	11	13	15
G (H8)	50	60 {60}	70 [110] {70}	115 {115}	130	152	170
G ₁ (h8)	55	60	70	80	95	110	130
H	40	50	60	72	86	103	127,5
H ₁	57	71,5	84	102	119	135	167,5
H ₂	13	15	20	22	26	33	42,5
H ₃	40	40	40	40	50	50	60
I	28	40	50	60	70	85	110
I ₁	28	28	28	28	40	40	50
K	79,5	118,5	129	145,5	143,5	199	203
K ₁	57,5	57,5	57,5	57,5	70,5	70,5	83 - 88*
L	20	20	20	20	23	23	30
M	50	50	50	50	65	65	75
M ₁	16,3	21,8	27,3	28,3	31,3	35,3	45,3
M ₂	10,2	10,2	10,2	10,2	12,5	12,5	16
N ₁	5	6	8	8	8	10	12
N ₂	3	3	3	3	4	4	5
P	53	69 {99}	93 [90,5] {123}	86 {116}	111	111	131
P ₁	75	86	100	110	130	160	200
P ₂	23	28 {58}	44 [41,5] {74}	25 {56}	51	50	53,5
R	68	87 {87}	90 [130] {90}	150,5 {150,5}	165	175	230
R ₁	65	75	85	95	115	130	165
S	27,5	38,5	46,5	57	57	67	74
S ₁	6	7	8	10	11	14	13
S ₂	2,5	2,5	3	3	3	3	3,5
S ₃	30	30	30	30	41	41	49
U	10	4 {4}	5 [11] {5}	6,5 {6,5}	12	6	5
V	7	9 {9}	10,5 [9] {9}	11 {11}	13	13	14
V ₁	M6x10 (4)	M6x8,5 (4)	M8x10 (4)	M8x16 (8)	M8x16 (8)	M10x18 (8)	M10x21 (8)
V ₂	M4x10	M4x10	M4x10	M4x10	M4x10	M4x10	M6x15
Y ₁	80	90	90	90	120	120	120
Z	7	6 {8}	10 [13] {10}	10 {10}	14	16	18

D* - Bores on request

V1 - 90° for RT28

(*) - IEC71-B14 (FRS50)

Motor Dimensions: page 25

Not binding dimensions

Gear boxes Series RS and RT

Dimensions

Accessories RT

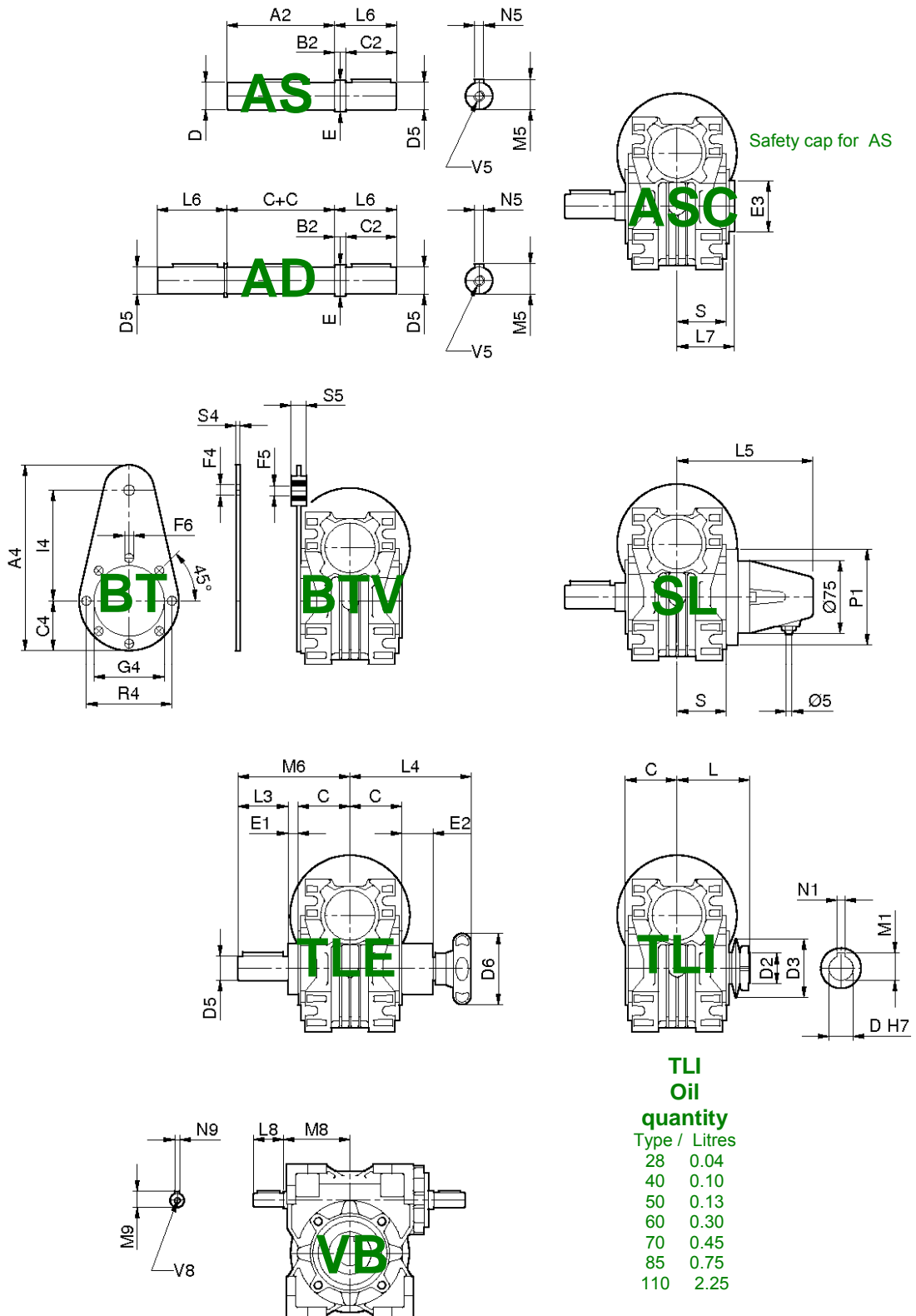

Gear boxes Series RS and RT

Accessories RT

Dimensions

RT	28	40	50	60	70	85	110
AS & AD A ₂	58	80	95	117	117	119	153
B ₂	1	10	10	10	10	10	10
C	30	41	49	60	60	61	77.5
C ₂	30	40	45	50	60	70	100
D ₅ (g6)	14	19 (18)	24 (25)	25	28	32 (35)	42
E	14	22	28	30	34	38	50
L ₆	31	50	55	60	70	80	110
M ₅	16	21.5	27	28	31	35	45
N ₅	5	6	8	8	8	10	12
V ₅	M5x10	M8x20	M8x20	M8x20	M8x20	M10x25	M10x25
ASC E ₃	50	52	62	75	90	100	120
L ₇	36	48.5	55.5	68.5	67	77	85
S	27.5	38.5	46.5	57	57	67	74
BT & BTV A ₄	138	168	185	235	295	313	388
C ₄	38	43	60	55	65	75	100
F ₄	10.5	10.5	10.5	10.5	10.5	20.5	20.5
F ₅	10	10	10	10	10	20	20
F ₆	7	7	9	9	9	12	13
G ₄	55	60	70	80	95	110	130
I ₄	80	100	100	150	150	200	250
R ₄	65	75	85	95	115	130	165
S ₄	4	4	4	6	6	6	6
S ₅	15	15	15	20	20	25	25
SL L ₅	96	113	123	133	133	139	150
P ₁	78	90	100	110	130	160	200
S	27.5	38.5	46.5	57	57	67	74
TLE D ₆	52	70	70	70	80	100	100
E ₁	10	12	12	15	14	19	24
E ₂	28	37	31	40	46	57	71
L ₃	30	40	50	50	60	70	80
L ₄	94	116	118	128	146	168	201
M ₆	70	93	111	125	134	150	181
TLI D (H7)	14	19	24	25	28	32	42
D ₂	40	56	71	71	80	90	125
D ₃	14.2 x 20	19.5 x 20.5	24.5 x 28	25.5 x 26	28.5 x 22	32.5 x 27	42.5 x 38.5
L	45	61.5	77	86.5	89	94	109
M ₁	15.4*	21.8	27.3	27.3*	31.3	35.3	45.3
N ₁ (H9)	5	6	8	8	8	10	12
VB D ₉	9	11	14	19	19	24	28
L ₈	20	23	30	40	40	50	60
M ₈	43	55	65	77	84	106.5	145
M ₉	10.2	12.5	16	22.5	22.5	27	31
N ₉	3	4	5	6	6	8	8
V ₈	M4x10	M4x10	M6x15	M8x20	M8x20	M8x20	M8x20

D₅ (..) = Diametre on request

* = Undersized key

Not binding dimensions

Gear boxes Series RS and RT

Dimensions

One stage helical attachment XA

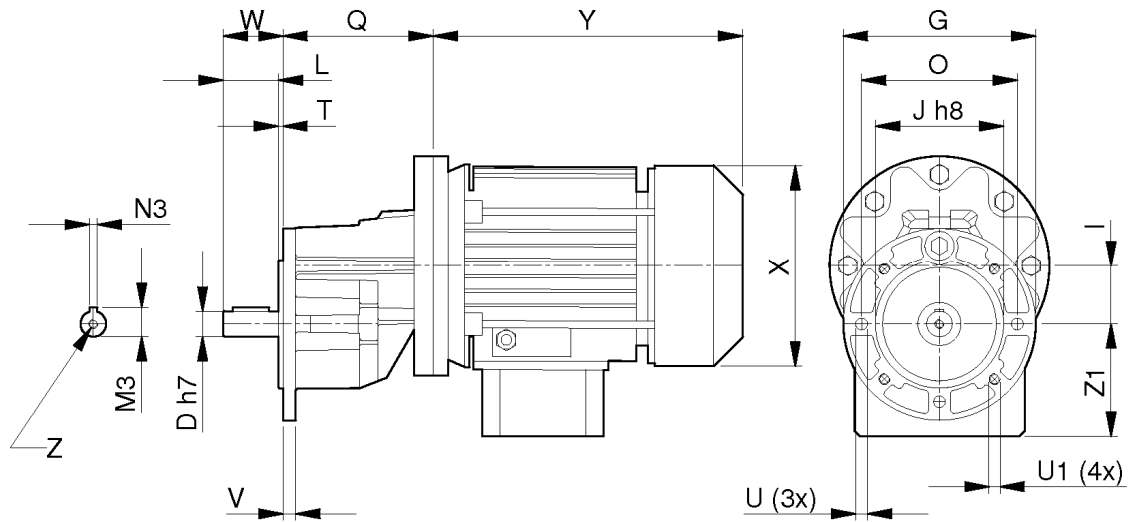

XA	D _{H7}	G	I	J _{h8}	L	O	Q	U	U1	T	V	W	Z
63	14	105	32	70	30	85	83	6.5	M6	2.5	7	32.5	M5x10
71	19	120	40	80	40	100	90	5.5	M6	2.5	7.5	42.5	M8x20
80	24	140	50	95	49.5	115	114	9	M8	2.5	10.5	52	M8x20
100	28	200	63	130	57,5	165	177	10,5	10,5	2,5	12	60	M10 x 22

IEC	56	63	71	80	90 S / L	100	112
H	108	110	121	138	149	160	160
X	168	185	215	238	255 / 280	309	309
Y	110	123	140	159	176	195	195

Gear boxes Series RS and RT

Back-driving and Self-locking

When back-driving a worm gear set using the worm wheel as input, the efficiency is lower than forward-driving and, by varying the design data, back-drive efficiency can be reduced to zero obtaining a self-locking, or irreversible, gear set,

When back-driving the worm gear, internal friction tends to lock the mesh, and the bigger the applied torque is, the more mesh friction increases proportionally augmenting the lockage at the same time.

The most obvious example is during braking or slowing-down where the inertial load will try to back-drive the worm shaft,

A worm gear is intended as a self-locking unit when the lead angle is less than the friction angle (arc tangent of friction coefficient),

Tooth contact is dynamic even when the mesh velocity is zero, as vibrations in a non-rotating gear set can induce motion in the tooth contact,

To provide a safety factor, a 3° lead angle is recommended for full self-locking condition, and 10° lead angle for poor self-locking condition, according to the table of relations between lead angles and self-locking.

Lead angle	Static self-locking
$\beta > 20^\circ$	Full reversibility
$10^\circ < \beta < 20^\circ$	High reversibility
$5^\circ < \beta < 10^\circ$	Good reversibility Poor self-locking
$3^\circ < \beta < 5^\circ$	Poor reversibility Good self-locking
$1^\circ < \beta < 3^\circ$	Full self-locking

Gear boxes Series RS and RT

Back-driving and Self-locking

	i =	5	7	10	15	20	28	40	49	56	70	80	100
RS/RT 28	m_x		1.50	1.40	1.40	1.10	1.50	1.10	0.90	0.75	0.60	0.55	0.45
	β	---	23°11'	16°41'	11°18'	10°23'	6°06'	5°14'	4°19'	3°03'	2°27'	2°37'	2°20'
	z_1		4	3	2	2	1	1	1	1	1	1	1
RS/RT 40	m_x	2,00	2.10	2.00	2.00	1.50	2.10	1.50	1.25	1.10	0.90	0.80	0.65
	β	30°57'	21°36'	16°41'	11°18'	8°31'	5°39'	4°17'	3°48'	3°25'	3°01'	2°51'	2°38'
	z_1	6	4	3	2	2	1	1	1	1	1	1	1
RS/RT 50	m_x	2,50	2.70	2.50	2.50	1.90	2.70	1.90	1.60	1.40	1.10	1.00	0.80
	β	30°57'	23°52'	16°41'	11°18'	5°59'	6°19'	4°31'	4°14'	3°42'	2°44'	2°51'	2°17'
	z_1	6	4	3	2	2	1	1	1	1	1	1	1
RS/RT 60	m_x	3,15	3.30	3.10	3.10	2.40	3.30	2.40	2.00	1.70	1.40	1.20	1.00
	β	36°32'	25°33'	19°0'	12°55'	11°18'	6°49'	5°42'	5°11'	3°55'	3°38'	2°51'	2°51'
	z_1	6	4	3	2	2	1	1	1	1	1	1	1
RS/RT 70	m_x	3,60	3.90	3.60	3.60	2.80	3.90	2.80	2.30	2.00	1.60	1.40	1.15
	β	34°01'	26°51'	18°38'	12°40'	11°18'	7°12'	5°42'	4°48'	4°05'	3°16'	2°51'	2°38'
	z_1	6	4	3	2	2	1	1	1	1	1	1	1
RS/RT 85	m_x	4,40	4.70	4.40	4.40	3.40	4.70	3.40	2.80	2.50	2.00	1.74	1.40
	β	34°47'	26°05'	19°09'	13°02'	11°18'	6°58'	5°52'	4°52'	4°45'	3°48'	3°14'	2°40'
	z_1	6	4	3	2	2	1	1	1	1	1	1	1
RS/RT 110	m_x		6.10	5.80	5.80	4.40	6.10	4.40	3.60	3.20	2.60	2.30	1.80
	β	---	26°22'	20°43'	14°09'	11°18'	7°04'	5°42'	4°43'	4°29'	3°54'	3°39'	2°34'
	z_1		4	3	2	2	1	1	1	1	1	1	1
RS 130	m_x		7.25	6.90	6.85	5.35	7.25	5.30	4.35	4.00	3.15	2.70	2.25
	β	---	26°57'	21°20'	14°06'	13°5'	7°14'	6°18'	5°18'	6°20'	4°33'	3°30'	3°40'
	z_1		4	3	2	2	1	1	1	1	1	1	1
RS 150	m_x		8.25	8.00	8.15	6.20	8.45	6.25	5.10	4.60	3.60	3.15	2.60
	β	---	25°33'	21°48'	16°22'	13°24'	7°35'	7°07'	5°48'	6°11'	4°17'	3°45'	3°43'
	z_1		4	3	2	2	1	1	1	1	1	1	1

m_x = Axial module
 z_1 = Number of starts
 β = Lead angle (rh)
 20° = Pressure angle

Gear boxes Series RS and RT

Direction of Rotation

WORMSHAFT UPWARDS

RS - RT

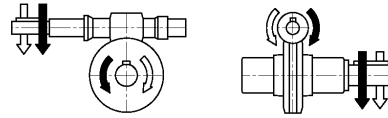

RA - TA

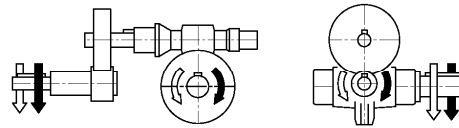

**RS/RS
RT/RT**

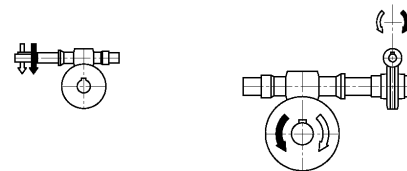

WORMSHAFT DOWNWARDS

RS - RT

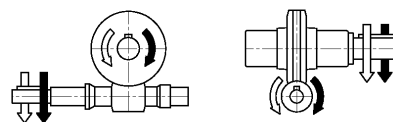

RA - TA

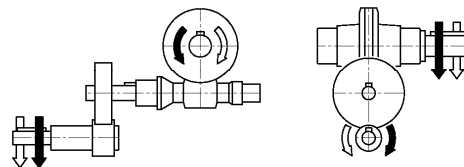

**RS/RS
RT/RT**



Gear boxes Series RS and RT

Abstract of OPERATION AND MAINTENANCE INSTRUCTIONS (complete manual on www.varvel.com)

Variable speed and reduction gearboxes are not part of the field of application of the Machinery Directive, art,1(2), and they must not be put into service until the machinery into which they are to be incorporated, has been declared in conformity with the provision of art,4(2), annex II(B) of Machinery Directives 98/37/CEE/22,6,98 and for Italy only, of DL 459/24,7,96.

Installation

Check if the unit to be installed, is properly selected to perform the required function and that its mounting position complies with the order.

The nameplate reports such information.

Check mounting stability to run the unit without vibrations or overloads.

Running

The unit may be connected for clockwise or counter-clockwise rotation.

The unit must be stopped as soon as defective running or unexpected noise occur, remove the faulty part or return the unit to the factory for checking.

If the faulty part is not replaced, other parts can also be affected, causing more severe damage and making the identification of initial cause more difficult.

Maintenance

Although the units are no-load run tested in the factory before despatch, it is recommended not to run them at maximum load for the first 20-30 running hours to allow the proper running in.

The gearboxes are delivered already filled with long-life synthetic oil and, in case of replacement or topping, do not mix with mineral lubricants.

Handling

When hoisting, use relevant housing locations or eyebolts if provided, or foot or flange holes.

Never hoist on any moving part.

Painting

Carefully protect oil seals, coupling faces and shafts when units are re-painted.

Long-term storage

For storages longer than 3 months, apply anti-oxidants onto shafts and machined surfaces, and protective grease on oil seal lips.

Product's Environmental Management

In conformity with Environmental Certification ISO 14001, we recommend the following to dispose of our products:

- scraped components of the units to deliver to authorized centres for metal object collection;
- oils and lubricants drained from the units to deliver to Exhausted Oil Unions;
- packages (pallets, carton boxes, paper, plastic, etc.) to lead into regeneration/recycling circuits as far as possible, by delivering separate waste classes to authorized companies.

Directive 84/9/CE - ATEX

Directive involves not only electrical machines but also every apparatus and control devices to be used in potentially explosive atmosphere.

The products VARVEL-ATEX are designed and manufactured according to Directive 94/9/CE and they are therefore qualified to installation in potentially explosive atmosphere.